

Model WCM 7300ME

Bulletin SSIN017 Issue/Rev. 0.2 (1/23)



Temperature Compensated Water Cut Monitor (WCM) with Insertion Probe

The Model WCM 7300M is designed to provide the highest possible sensitivity, resolution, and accuracy for water content determination in crude oil, other hydrocarbons, or other low dielectric liquids from a maximum of 25% to 1,000 parts per million (ppm). In oil and natural gas (condensate) production, water cut measurements are significantly improved with the WCM 7300ME technology. Enhanced digital signal processing and full product temperature compensation are two of the technological advancements applied by this device. Water cut, process temperature, or probe electrical value can be selected for viewing without removing conduit cover by use of a supplied magnet to operate an internal reed switch. The Model WCM 7300ME is NACE adaptable and can be modified for use in NACE applications. It is often more economical to use an insertion probe than an inline on large diameter flow lines.

Product Temperature Compensation

The base dielectric constant (Dk) of oils can change with changes in temperature. This can cause traditional monitors to change without a variance in water content. For example: For a 10 °F change, a typical crude oil may show a reading shift of as much as 0.1%, which normally would be considered as water. The WCM 7300ME measures product temperature and calculates a corrected cut reading, providing a true water cut at any temperature between 25 °F and 160 °F.

Applications

- LACT (Lease Automatic Custody Transfer) units—Detect and provide relay contact closure that can be used to reroute oil that has excess Water Cut
- Pipeline loading—Monitor the transfer of petroleum/condensate products from loading facilities.
- Dehydration equipment—Determine and enhance equipment efficiencies by monitoring the product and indicating water content.
- Fuel oil monitoring—Determine contamination of fuel oil by condensation or other external factors before entry to engine.
- Storage and treating facilities—Monitor and detect undesirable conditions, as well as interface detection during dewatering of storage tanks.

Specifications

Power Supply

20-30 volts direct current (VDC) +/-10% at nominal, 100 milliampere (mA) maximum

Water Cut Monitor Full Scale Range

0-25%

Display

Four digit liquid crystal display (LCD) with decimal point.

Analog Outputs

4-20 mA, two-wire internally powered or 4-20 mA, three-wire externally powered

Relay Output

- Single pole double throw relay (SPDT), 10A, 250 VAC
- 1/2 Hp 250 volts of alternating current (VAC), 10A-120 VAC resistive
- 1/3 Hp 120 VAC, 10A-30 VDC resistive

Time Relay

- Zero to 99 seconds adjustable in one second increments
- Off-delay approximately 10% of on-delay time

Temperature Range

0 to 160 °F (-20 to 70 °C)

Enclosures

- NEMA 4X, weatherproof
- NEMA 7, explosion-proof, Class I, Division 1, Groups C and D

Normal Variances

- +/- .05 from 0 to 5% water
- +/- .1 from 5 to 10% water
- +/- .15 from 10 to 15% water
- +/- .2 to .25 from 15 to 25% water

Displays

Two lines 16-character, alphanumeric LCD showing by selection:

- Water cut
- Process temperature
- Probe electrical value

Red/green light emitting diode (LED) displaying good oil, bad oil, or by passing condition.

Pressure Ratings

- As per flange selection: 1440 pounds-force per square inch gauge (psig) maximum; others by special order
- National pipe thread (NPT): 1440 psig maximum
- Victaulic grooved: 350 psig

WCM 7300ME Insterion Probes Dimensions

The following dimensions are for the 2" probe. The 3" face to end is 18.00" instead of 33.00".

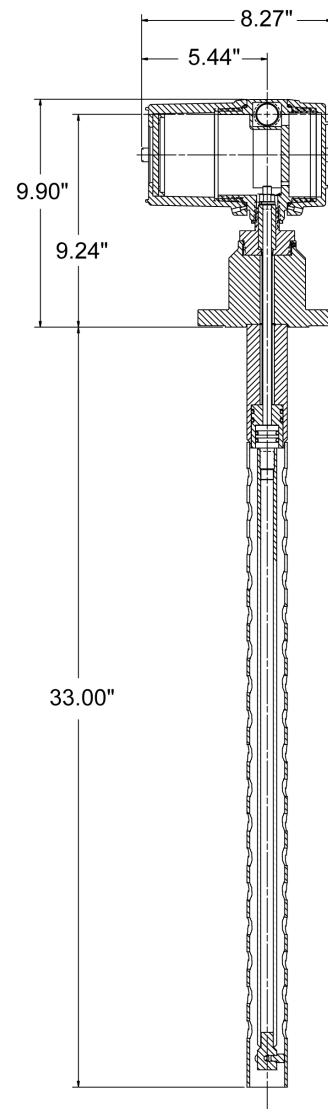

Modeling Code and Ordering Information

Note: Consult the factory for temperature compensation factor.

WCM 7300ME		Insertion-style Water Cut Monitor: Digital, Temperature Compensating, Ranges from 0 - 25% Water				
		Probe Material: Carbon Steel				
		Code	Probe Body Size			
		2	2 inch O.D.			
		3	3 inch O.D.			
			Code	End Connections		
			00	Screwed ends		
			00	Grooved ends/Victaulic		
			00	150 lb ANSI raised face		
			30	300 lb ANSI raised face		
			60	600 lb ANSI raised face (SCH 80) (For 8 inch and 10 inch)		
			90	900 lb ANSI raised face (SCH 80)		
			05	150 lb ANSI RTJ		
			35	300 lb ANSI RTJ		
			65	600 lb ANSI RTJ (SCH 80) (For 8 inch and 10 inch)		
			95	900 lb ANSI RTJ (SCH 80)		
			115	1500 lb ANSI RTJ (SCH 160)		
				Code	Material and Temperature Options	
				B	Standard materials, A53B carbon steel, -20 - 160 ° F	
				H	Standard materials/high temperature, -20 - 375 ° F	
				S	316 stainless steel materials, -20 - 160 ° F	
				T	316 stainless steel/high temperature, -20 - 375 ° F	
					Code	Connection Style
					S	Screwed connections, male national pipe thread (MNPT)
					G	Victaulic connections (grooved)
					F	Flanged connections
						Code Open
					P	Epoxy
Example:						
WCM 7300ME -	2	60 -	B	F	P	= WCM 7300ME - 260 - BFP

Choose one code selection from each option group to build model number and correct pricing.

The specifications contained herein are subject to change without notice and any user of said specifications should verify from the manufacture that the specifications are currently in effect. Otherwise, the manufacturer assumes no responsibility for the use of specifications which may have been changed and are no longer in effect.

TechnipFMC.com

Copyright © 2023 TechnipFMC plc. All rights reserved.

TechnipFMC Corporate Headquarters
13460 Lockwood Road
Building S01
Houston, TX 77044 USA
+1 281.591.4000

USA Operations
1602 Wagner Avenue
Erie, PA 16510 USA
+1 814.898.5000

Germany Operations
Smith Meter GmbH
Regentstrasse 1
25474 Ellerbek, Germany
+49 4101 304.0