

Rosemount™ 5408 and 5408:SIS Level Transmitters

Non-Contacting Radar



- Unique energy-efficient two-wire FMCW radar technology for optimal performance
- Engineered and user tested for best in class safety, reliability, and ease-of-use
- Built on 40 years of inventing and redefining radar level measurement
- Intuitive commissioning experience driven by wizards and adaptive graphics
- Rosemount 5408:SIS, optimal for safety applications and IEC 61508 certified to SIL 2
- Safe, easy, and remote proof testing without process interruptions

Introduction

Measurement principle

The Rosemount™ 5408 and 5408:SIS are two-wire transmitters for continuous level measurements over a broad range of liquids, slurries, and solids. The measurement principle is fast-sweep Frequency Modulated Continuous Wave (FMCW).

Radar signals are continuously transmitted towards the product surface with a microwave frequency modulated over a span. The level is proportional to the frequency difference between currently received and transmitted signal.

Figure 1: FMCW-method

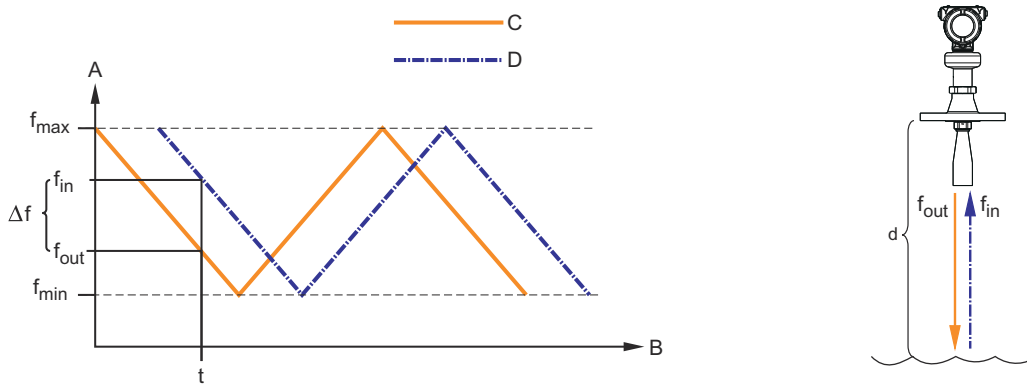

$\Delta f \approx d = \text{distance}$

- A. Frequency (GHz)
- B. Time (s)
- C. Transmitted signal
- D. Reflected signal

Technology to redefine reliability

The Rosemount 5408 and 5408:SIS are optimized for reliable and accurate performance even in challenging process conditions. FMCW technology maximizes radar signal strength and produces a robust and reliable measurement (with 30 times more power on the surface than traditional two-wire non-contacting radars).

The transmitters can operate with only 12 Vdc lift-off voltage and they are self-powered for up to 2 seconds to maintain operation despite cable glitches or lightning.

Contents

Introduction	2
Ordering Information	6
Specifications	18
Product Certifications	41
Dimensional drawings	59

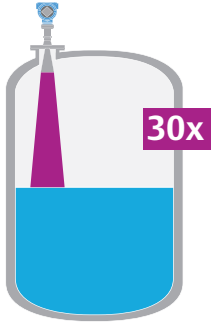

Ease-of-use at every touch point

The Rosemount 5408 and 5408:SIS are designed to simplify operator tasks. They deliver ease-of-use at every touch point, from the pictorial user instructions and graphical, intuitive wizards to the PTFE seal that requires no O-ring material for simplifying model selection.

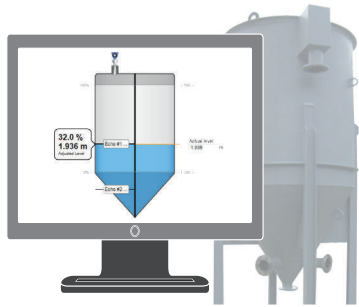

Dedicated to safety

The Smart Diagnostics Suite provides operators with early alerts in case of antenna build-up, weak power supply, or abnormal surface conditions. Also, a local memory enables full insight into the last seven days of measurements, alerts, and echo profiles.

The Rosemount 5408:SIS is the ideal choice for functional safety such as overflow prevention. It is safety certified (SIL 2/SIL 3), supports long proof-test intervals guaranteed to suit your schedule, and can be tested remotely without any process interruption.

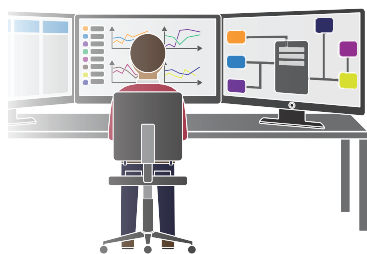

Application examples

The Rosemount 5408 and 5408:SIS are ideal for level measurements over a broad range of liquid and solids applications. The transmitters are virtually unaffected by changing density, temperature, pressure, media dielectric, pH, and viscosity. Non-contacting radar level is ideal for harsh conditions such as corrosive and sticky media, or when internal tank obstructions are a limiting factor.

Storage and buffer tanks

The Rosemount 5408 provides accurate and reliable level measurement for both metallic or non-metallic vessels containing almost any liquid (e.g. oil, gas condensate, water, chemicals).

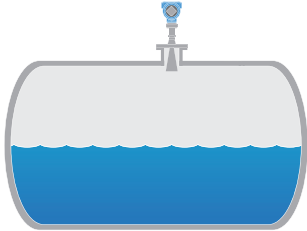

Reactors

The Rosemount 5408 is ideal for the most challenging applications, including reactors where there can be agitation, foaming, condensation as well as high temperatures and pressures.

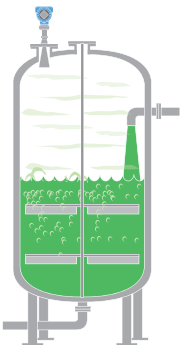

Blenders and mixers

The Rosemount 5408 can help you withstand the rigors of blenders and mixing tanks. Easy to install and commission, it is also unaffected by virtually any fluid property change.

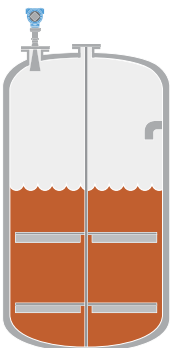

Open atmospheric applications

The Rosemount 5408 measures reliably in open applications, from short range sumps or ponds to long range dams.

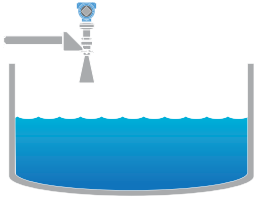

Still pipe and chamber installations

The Rosemount 5408 is an excellent choice for level measurement in tanks with still pipes. It may also be used in chambers, but guided wave radar is generally the best fit for these applications. See [Still pipe/chamber installations](#) for installation guidelines.

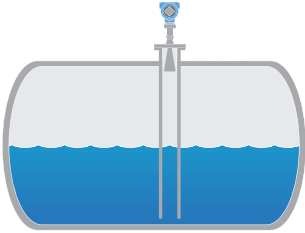

Bulk solids

The Rosemount 5408 is the ideal solution for small to medium sized silos with rapid level changes. The narrow beam avoids internal obstructions while still keeping good level measurement.



Safety applications

The Rosemount 5408:SIS is the ideal choice for safety functions such as overflow prevention, level deviation monitoring or dry-run prevention.

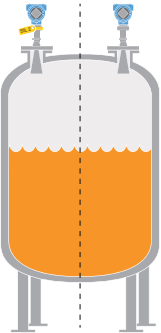

Ordering Information

Rosemount 5408 Level Transmitter

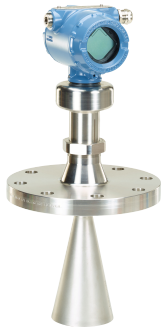

The Rosemount 5408 is a two-wire non-contacting radar transmitter for level measurements over a broad range of liquids and slurries. It uses a unique energy efficient radar technology based on the FMCW principle to ensure reliable performance even in challenging conditions.

Specification and selection of product materials, options, or components must be made by the purchaser of the equipment. See [Material selection](#) for more information on material selection.

The starred offerings (★) represent the most common options and should be selected for best delivery. The non-starred offerings are subject to additional delivery lead time.

Table 1: Rosemount 5408 Level Transmitter Ordering Information

Model	Product Description	
5408	Radar Level Transmitter	★
Profile		
A	Standard Monitoring & Control Applications	★
Measurement type		
1	Liquid Level Measurement	★
3	Solids Level Measurement	★
4	Liquid & Solids Level Measurement	★
Performance class		
S	Standard	★
Signal output		
H	4–20 mA with digital signal based on HART® Revision 6 protocol (HART Revision 7 available as option)	★
Housing material		
A	Aluminum	★
S	Stainless Steel (SST)	★
Conduit/cable threads		
1	½-14 NPT	★
2	M20 x 1.5	★
3 ⁽¹⁾	G½	
Hazardous locations certifications		
NA	None	★
E1	ATEX Flameproof	★

Table 1: Rosemount 5408 Level Transmitter Ordering Information (continued)

I1	ATEX Intrinsic Safety		★
N1	ATEX Type n		★
E5	USA Explosion-proof, Dust Ignition-proof		★
I5	USA Intrinsically Safe; Nonincendive		★
E6	Canadian Explosion-proof, Dust Ignition-proof		★
I6	Canadian Intrinsically Safe; Nonincendive		★
E7	IECEX Flameproof, Dust Ignition-proof		★
I7	IECEX Intrinsic Safety		★
N7	IECEX Type n		★
E2	INMETRO Flameproof		★
I2	INMETRO Intrinsic Safety		★
N2	INMETRO Type n		★
E3	China Flameproof		★
I3	China Intrinsic Safety		★
N3	China Type n		★
IP	Republic of Korea Intrinsic Safety		★
Materials of construction		Available antenna types	
1	316/316L/EN 1.4404	Cone, Parabolic	★
7	All PTFE Wetted Parts	Process Seal	★
2	Alloy C-276 (UNS N10276) with Protective Plate	Cone	
3	Alloy 400 (UNS N04400) with Protective Plate	Cone	
H	Alloy C-276 (UNS N10276) Process Connection, Flange, and Antenna	Cone	
M	Alloy 400 (UNS N04400) Process Connection, Flange, and Antenna	Cone	
Process connection type (see Table 3, Table 4, Table 5, and Table 6)		Available antenna types	
F ⁽²⁾	Flat Face Flange	Cone, Parabolic	★
R ⁽³⁾	Raised Face Flange	All	★
N	NPT Thread	Cone	★
G	BSPP (G) Thread	Cone, Parabolic	★
B	Bracket Mounting	Cone	★
C	Tri-Clamp [®]	Process Seal	★
W	Welded Connection	Parabolic	★
Process connection size (see Table 3, Table 4, Table 5, and Table 6)		Available antenna types	
A	1½-in.	Cone	★
2	2-in./DN50/50A	Cone, Process Seal	★
3	3-in./DN80/80A	Cone, Process Seal	★
B	3½-in.	Parabolic	★
4	4-in./DN100/100A	Cone, Process Seal	★

Table 1: Rosemount 5408 Level Transmitter Ordering Information (continued)

6	6-in./DN150/150A	Cone	★
8	8-in./DN200/200A	Cone, Parabolic	★
T	10-in./DN250/250A	Parabolic	★
Z	None (use when ordering bracket mounting)	Cone	★
Process connection rating (see Table 3, Table 4, Table 5, and Table 6)			
ZZ	For use with non-flange process connection type		★
ASME flanges			
AA	ASME B16.5 Class 150		★
AB	ASME B16.5 Class 300		★
AC	ASME B16.5 Class 600		★
EN flanges		Note	
DK	EN1092-1 PN6	N/A	★
DA	EN1092-1 PN16	PN10 and PN16 dimensions are identical for DN50 to DN150	★
DB	EN1092-1 PN40	PN25 and PN40 dimensions are identical for DN50 to DN150	★
DC	EN1092-1 PN63	N/A	★
DD	EN1092-1 PN100	N/A	★
JIS flanges			
JK	JIS 5K		★
JA	JIS 10K		★
JB	JIS 20K		★
Antenna type		Operating pressure	Operating temperature
CAA	Cone Antenna (PTFE seal)	-15 to 363 psig (-1 to 25 bar)	-76 to 392 °F (-60 to 200 °C) ★
CAB	Cone Antenna (PTFE seal)	-15 to 725 psig (-1 to 50 bar) ⁽⁴⁾	-40 to 302 °F (-40 to 150 °C) ★
CAC	Cone Antenna (PTFE seal)	-15 to 1450 psig (-1 to 100 bar)	-40 to 212 °F (-40 to 100 °C) ★
CAD	Cone Antenna (PTFE seal)	-15 to 44 psig (-1 to 3 bar)	-76 to 482 °F (-60 to 250 °C) ★
CBF	Cone Antenna (PEEK seal, FVMQ)	-15 to 754 psig (-1 to 52 bar)	-76 to 338 °F (-60 to 170 °C) ★
CBK	Cone Antenna (PEEK seal, Kalrez® 6375)	-15 to 754 psig (-1 to 52 bar)	5 to 482 °F (-15 to 250 °C) ★
CBM	Cone Antenna (PEEK seal, FKM)	-15 to 754 psig (-1 to 52 bar)	-13 to 428 °F (-25 to 220 °C) ★
CBV	Cone Antenna (PEEK seal, Viton®)	-15 to 754 psig (-1 to 52 bar)	-22 to 392 °F (-30 to 200 °C) ★
SAA	Process Seal Antenna	-7 to 363 psig (-0.5 to 25 bar) ⁽⁵⁾	-76 to 392 °F (-60 to 200 °C) ⁽⁵⁾ ★
PAS	Parabolic Antenna, Swivel Mount	-7 to 43 psig (-0.5 to 3 bar)	-67 to 392 °F (-55 to 200 °C) ★
Antenna size			Available antenna types
2	2-in. (DN50)		Cone, Process Seal ★
3	3-in. (DN80)		Cone, Process Seal ★
4	4-in. (DN100)		Cone, Process Seal ★
8	8-in. (DN200)		Parabolic ★

Table 1: Rosemount 5408 Level Transmitter Ordering Information (continued)

Options (include with selected model number)			
Antenna extensions (see Figure 20)		Total length	
S1	Extended Cone Antenna	24-in. (600 mm)	★
S2	Extended Cone Antenna, Segmented	48-in. (1200 mm)	★
Purging connection (see Figure 12)⁽⁶⁾⁽⁷⁾			
PC1	Purging Connector (Purge Ring)		★
Display			
M5	LCD Display		★
Functional safety options			
EF1	Ready for upgrade to Rosemount 5408:SIS		★
Diagnostic functionality			
DA1	Smart Diagnostics Suite (see Smart Diagnostics Suite (option code DA1))		★
HART revision configuration			
HR7	4-20 mA with digital signal based on HART Revision 7 protocol		★
Open air applications configuration ⁽⁸⁾			
OA	Open Air Applications Configuration; LPR (Level Probing Radar)		★
Factory configuration			
C1	Factory Configuration per Configuration Data Sheet		★
Alarm limits			
C4	NAMUR Alarm and Saturation Levels, High Alarm		★
C5	NAMUR Alarm and Saturation Levels, Low Alarm		★
C8 ⁽⁹⁾	Standard Rosemount Alarm and Saturation Levels, Low Alarm		★
Welding standard for flanges ⁽¹⁰⁾			
AW	According to ASME IX		★
EW	According to EN-ISO		★
Country certification⁽¹¹⁾			
J1	Canadian Registration (CRN)		★
Special quality assurance			
Q4	Calibration Data Certificate		★
Hydrostatic testing ⁽¹²⁾			
Q5	Hydrostatic Testing, including certificate		★
Material traceability certification ⁽¹³⁾			
Q8	Material Traceability Certification per EN 10204 3.1 (2.1 for non-metallic)		★
Hygienic certification⁽¹⁴⁾			
QA	Certificate of compliance to 3-A [®]		★

Table 1: Rosemount 5408 Level Transmitter Ordering Information (continued)

Materials certification ⁽¹⁵⁾		
Q15	NACE® Material Recommendation per NACE MR0175/ISO 15156	★
Q25	NACE Material Recommendation per ANSI/NACE MR0103/ISO 17495-1	★
Q35	NACE Material Recommendation per NACE MR0175/ISO 15156 and ANSI/NACE MR0103/ISO 17495-1	★
Welding procedure qualification record documentation⁽¹⁰⁾		
Q66	Welding Procedure Qualification Record (WPQR)	★
Q67	Welder Performance Qualification (WPQ)	★
Q68	Welding Procedure Specification (WPS)	★
Q79	WPQR/WPQ/WPS	★
Dye penetration test certificate⁽¹⁰⁾		
Q73	Certificate of Liquid Penetrant Inspection	★
Positive material identification certificate		
Q76	Positive Material Identification Certificate of Conformance	★
Overfill prevention		
U1	Overfill Prevention According to WHG/TUV	★
Extended product warranty		
WR3	3-year Limited Warranty	★
WR5	5-year Limited Warranty	★
Conduit electrical connector (shipped uninstalled) ⁽¹⁶⁾		
EC	M 12, 4-pin, Male connector (eurofast®)	★
MC	A size Mini, 4-pin, Male connector (minifast®)	★
Specials (see Engineered solutions)		
PXXXX	Custom Engineered Solutions beyond standard model codes. Consult factory for details.	
Typical model number: 5408 A 1 S H A 1 E5 1 R 3 AB CAB 3 M5 DA1		

- (1) *G½ thread form is not available with hazardous locations approvals.*
- (2) *Type A flat face for EN 1092-1 flanges.*
- (3) *Type B1 raised face for EN 1092-1 flanges.*
- (4) *Pressure limit is derated for process temperatures above 100 °F (38 °C), see [Figure 6](#) for details.*
- (5) *Refer to [Figure 8](#) for pressure/temperature ratings of Tri-Clamp connection.*
- (6) *Option code PC1 is for cone antennas only, and requires matching flange and antenna sizes. Note that all parabolic antennas come with an integrated air purge connection.*
- (7) *A minimum gasket thickness of 0.125 in. (3.2 mm) is required for flanges with protective plate design.*
- (8) *Only available with parabolic antenna and 4-in. (DN100) cone antenna.*
- (9) *The standard alarm setting is high.*
- (10) *Only applies to flanged process connections with welded construction or protective plate design; only applicable to cone antennas (see [Table 3](#) and [Table 4](#)).*
- (11) *Only available with ASME B16.5 flange connections, and materials of construction codes 1 and 7.*
- (12) *Hydrostatic testing is only available for cone antennas and process seal antennas with flanged process connections.*
- (13) *Certificate includes all pressure retaining and wetted parts.*
- (14) *Only available for process seal antennas with Tri-Clamp connection.*
- (15) *Not available with parabolic antenna.*
- (16) *Requires ½-14 NPT conduit/cable threads (code 1). Available with Intrinsically Safe approvals only.*

Rosemount 5408:SIS Level Transmitter



Safety certified to IEC 61508 for SIL2 applications with SIL3 capability, the Rosemount 5408:SIS reduces cost of risk, increases efficiency and protects your staff and the environment.

Specification and selection of product materials, options, or components must be made by the purchaser of the equipment. See [Material selection](#) for more information on material selection.

The starred offerings (★) represent the most common options and should be selected for best delivery. The non-starred offerings are subject to additional delivery lead time.

Table 2: Rosemount 5408:SIS Level Transmitter Ordering Information

Model	Product Description	
5408	Radar Level Transmitter	★
Profile (1)		
F	Functional Safety / SIS Applications	★
Measurement type		
1	Liquid Level Measurement	★
4 (2)	Liquid & Solids Level Measurement	★
Performance class		
S	Standard	★
Signal output		
H	4–20 mA with digital signal based on HART Revision 6 protocol (HART Revision 7 available as option)	★
Housing material		
A	Aluminum	★
S	Stainless Steel (SST)	★
Conduit/cable threads		
1	½-14 NPT	★
2	M20 x 1.5	★
3 (3)	G½	
Hazardous locations certifications		
NA	None	★
E1	ATEX Flameproof	★
I1	ATEX Intrinsic Safety	★
N1	ATEX Type n	★
E5	USA Explosion-proof, Dust Ignition-proof	★
I5	USA Intrinsically Safe; Nonincendive	★

Table 2: Rosemount 5408:SIS Level Transmitter Ordering Information (continued)

E6	Canadian Explosion-proof, Dust Ignition-proof		★
I6	Canadian Intrinsically Safe; Nonincendive		★
E7	IECEX Flameproof, Dust Ignition-proof		★
I7	IECEX Intrinsic Safety		★
N7	IECEX Type n		★
E2	INMETRO Flameproof		★
I2	INMETRO Intrinsic Safety		★
N2	INMETRO Type n		★
E3	China Flameproof		★
I3	China Intrinsic Safety		★
N3	China Type n		★
IP	Republic of Korea Intrinsic Safety		★
Materials of construction		Available antenna types	
1	316/316L/EN 1.4404	Cone, Parabolic	★
7	All PTFE Wetted Parts	Process Seal	★
2	Alloy C-276 (UNS N10276) with Protective Plate	Cone	
3	Alloy 400 (UNS N04400) with Protective Plate	Cone	
H	Alloy C-276 (UNS N10276) Process Connection, Flange, and Antenna	Cone	
M	Alloy 400 (UNS N04400) Process Connection, Flange, and Antenna	Cone	
Process connection type (see Table 3, Table 4, Table 5, and Table 6)		Available antenna types	
F ⁽⁴⁾	Flat Face Flange	Cone, Parabolic	★
R ⁽⁵⁾	Raised Face Flange	All	★
N	NPT Thread	Cone	★
G	BSPP (G) Thread	Cone, Parabolic	★
B	Bracket Mounting	Cone	★
C	Tri-Clamp	Process Seal	★
W	Welded Connection	Parabolic	★
Process connection size (see Table 3, Table 4, Table 5, and Table 6)		Available antenna types	
A	1½-in.	Cone	★
2	2-in./DN50/50A	Cone, Process Seal	★
3	3-in./DN80/80A	Cone, Process Seal	★
B	3½-in.	Parabolic	★
4	4-in./DN100/100A	Cone, Process Seal	★
6	6-in./DN150/150A	Cone	★
8	8-in./DN200/200A	Cone, Parabolic	★
T	10-in./DN250/250A	Parabolic	★
Z	None (use when ordering bracket mounting)	Cone	★

Table 2: Rosemount 5408:SIS Level Transmitter Ordering Information (continued)

Process connection rating (see Table 3 , Table 4 , Table 5 , and Table 6)			
ZZ	For use with non-flange process connection type		★
ASME flanges			
AA	ASME B16.5 Class 150		★
AB	ASME B16.5 Class 300		★
AC	ASME B16.5 Class 600		★
EN flanges		Note	
DK	EN1092-1 PN6	N/A	★
DA	EN1092-1 PN16	PN10 and PN16 dimensions are identical for DN50 to DN150	★
DB	EN1092-1 PN40	PN25 and PN40 dimensions are identical for DN50 to DN150	★
DC	EN1092-1 PN63	N/A	★
DD	EN1092-1 PN100	N/A	★
JIS flanges			
JK	JIS 5K		★
JA	JIS 10K		★
JB	JIS 20K		★
Antenna type	Operating pressure	Operating temperature	
CAA	Cone Antenna (PTFE seal)	-15 to 363 psig (-1 to 25 bar)	-76 to 392 °F (-60 to 200 °C) ★
CAB	Cone Antenna (PTFE seal)	-15 to 725 psig (-1 to 50 bar) ⁽⁶⁾	-40 to 302 °F (-40 to 150 °C) ★
CAC	Cone Antenna (PTFE seal)	-15 to 1450 psig (-1 to 100 bar)	-40 to 212 °F (-40 to 100 °C) ★
CAD	Cone Antenna (PTFE seal)	-15 to 44 psig (-1 to 3 bar)	-76 to 482 °F (-60 to 250 °C) ★
CBF	Cone Antenna (PEEK seal, FVMQ)	-15 to 754 psig (-1 to 52 bar)	-76 to 338 °F (-60 to 170 °C) ★
CBK	Cone Antenna (PEEK seal, Kalrez 6375)	-15 to 754 psig (-1 to 52 bar)	5 to 482 °F (-15 to 250 °C) ★
CBM	Cone Antenna (PEEK seal, FKM)	-15 to 754 psig (-1 to 52 bar)	-13 to 428 °F (-25 to 220 °C) ★
CBV	Cone Antenna (PEEK seal, Viton)	-15 to 754 psig (-1 to 52 bar)	-22 to 392 °F (-30 to 200 °C) ★
SAA	Process Seal Antenna	-7 to 363 psig (-0.5 to 25 bar) ⁽⁷⁾	-76 to 392 °F (-60 to 200 °C) ⁽⁷⁾ ★
PAS	Parabolic Antenna, Swivel Mount	-7 to 43 psig (-0.5 to 3 bar)	-67 to 392 °F (-55 to 200 °C) ★
Antenna size	Available antenna types		
2	2-in. (DN50)	Cone, Process Seal ★	
3	3-in. (DN80)	Cone, Process Seal ★	
4	4-in. (DN100)	Cone, Process Seal ★	
8	8-in. (DN200)	Parabolic ★	
Options (include with selected model number)			
Antenna extensions (see Figure 20)	Total length		
S1	Extended Cone Antenna	24-in. (600 mm) ★	
S2	Extended Cone Antenna, Segmented	48-in. (1200 mm) ★	

Table 2: Rosemount 5408:SIS Level Transmitter Ordering Information (continued)

Purging connection (see Figure 12) ⁽⁸⁾⁽⁹⁾		
PC1	Purging Connector (Purge Ring)	★
Display		
M5	LCD Display	★
Functional safety options		
EF2	Extended SIS Package	★
Diagnostic functionality		
DA1	Smart Diagnostics Suite (see Smart Diagnostics Suite (option code DA1))	★
HART revision configuration		
HR7	4-20 mA with digital signal based on HART Revision 7 protocol	★
Factory configuration		
C1	Factory Configuration per Configuration Data Sheet	★
Alarm limits		
C4	NAMUR Alarm and Saturation Levels, High Alarm	★
C5	NAMUR Alarm and Saturation Levels, Low Alarm	★
C8 ⁽¹⁰⁾	Standard Rosemount Alarm and Saturation Levels, Low Alarm	★
Welding standard for flanges ⁽¹¹⁾		
AW	According to ASME IX	★
EW	According to EN-ISO	★
Country certification⁽¹²⁾		
J1	Canadian Registration (CRN)	★
Special quality assurance		
Q4	Calibration Data Certificate	★
Hydrostatic testing ⁽¹³⁾		
Q5	Hydrostatic Testing, including certificate	★
Material traceability certification ⁽¹⁴⁾		
Q8	Material Traceability Certification per EN 10204 3.1 (2.1 for non-metallic)	★
Hygienic certification⁽¹⁵⁾		
QA	Certificate of compliance to 3-A	★
Quality certification for safety		
QS	Certificate of FMEDA Data	★
QT	Safety-certified to IEC 61508 with certificate of FMEDA data	★
Materials certification ⁽¹⁶⁾		
Q15	NACE Material Recommendation per NACE MR0175/ISO 15156	★
Q25	NACE Material Recommendation per ANSI/NACE MR0103/ISO 17495-1	★
Q35	NACE Material Recommendation per NACE MR0175/ISO 15156 and ANSI/NACE MR0103/ISO 17495-1	★

Table 2: Rosemount 5408:SIS Level Transmitter Ordering Information (continued)

Welding procedure qualification record documentation⁽¹¹⁾		
Q66	Welding Procedure Qualification Record (WPQR)	★
Q67	Welder Performance Qualification (WPQ)	★
Q68	Welding Procedure Specification (WPS)	★
Q79	WPQR/WPQ/WPS	★
Dye penetration test certificate⁽¹¹⁾		
Q73	Certificate of Liquid Penetrant Inspection	★
Positive material identification certificate		
Q76	Positive Material Identification Certificate of Conformance	★
Overfill prevention		
U1	Overfill Prevention According to WHG/TUV	★
Extended product warranty		
WR3	3-year Limited Warranty	★
WR5	5-year Limited Warranty	★
Paint option for aluminum housing		
PY1	Housing and Covers in Yellow per RAL 1003	★
PY2	Covers in Yellow per RAL 1003	★
PR1	Housing and Covers in Red per RAL 3002	★
PR2	Covers in Red per RAL 3002	★
PO1	Housing and Covers in Orange per Munsell 2.5 YR 6/14	★
PO2	Covers in Orange per Munsell 2.5 YR 6/14	★
Conduit electrical connector (shipped uninstalled) ⁽¹⁷⁾		
EC	M 12, 4-pin, Male connector (eurofast)	★
MC	A size Mini, 4-pin, Male connector (minifast)	★
Specials (see Engineered solutions)		
PXXXX	Custom Engineered Solutions beyond standard model codes. Consult factory for details.	
Typical model number: 5408 F 1 S H A 1 E5 1 R 3 AB CAB 3 M5 DA1 EF2 QT		

- (1) The Rosemount 5408:SIS has two operational modes: Safety (SIS) and Control/Monitoring. Safety (SIS) mode must be set when used in Safety Instrumented Systems. Control/Monitoring mode is intended for use in a Basic Process Control System (BPCS).
- (2) Solids level measurement is only available when operating in Control/Monitoring mode.
- (3) G½ thread form is not available with hazardous locations approvals.
- (4) Type A flat face for EN 1092-1 flanges.
- (5) Type B1 raised face for EN 1092-1 flanges.
- (6) Pressure limit is derated for process temperatures above 100 °F (38 °C), see [Figure 6](#) for details.
- (7) Refer to [Figure 8](#) for pressure/temperature ratings of Tri-Clamp connection.
- (8) Option code PC1 is for cone antennas only, and requires matching flange and antenna sizes. Note that all parabolic antennas come with an integrated air purge connection.
- (9) A minimum gasket thickness of 0.125 in. (3.2 mm) is required for flanges with protective plate design.
- (10) The standard alarm setting is high.

- (11) Only applies to flanged process connections with welded construction or protective plate design; only applicable to cone antennas (see [Table 3](#) and [Table 4](#)).
- (12) Only available with ASME B16.5 flange connections, and materials of construction codes 1 and 7.
- (13) Hydrostatic testing is only available for cone antennas and process seal antennas with flanged process connections.
- (14) Certificate includes all pressure retaining and wetted parts.
- (15) Only available for process seal antennas with Tri-Clamp connection.
- (16) Not available with parabolic antenna.
- (17) Requires ½-14 NPT conduit/cable threads (code 1). Available with Intrinsically Safe approvals only.

Availability of process connections

Table 3: Cone Antenna - 316/316L SST/EN 1.4404 (Type vs. Size and Rating)

Process connection size	Process connection rating									
	Thread ⁽¹⁾	ASME B16.5 flanges ⁽²⁾			EN1092-1 flanges ⁽²⁾				JIS B2220 flanges ⁽²⁾	
		Class 150 ⁽³⁾	Class 300 ⁽³⁾	Class 600 ⁽⁴⁾	PN16 ⁽⁵⁾	PN40 ⁽⁵⁾	PN63 ⁽⁴⁾	PN100 ⁽⁴⁾	10K ⁽³⁾	20K ⁽⁴⁾
1½-in.	G, N	N/A	N/A	N/A	N/A	N/A	N/A	N/A	N/A	N/A
2-in./DN50/50A	G, N	R	R	R	F	F, R	F, R	F	R	R
3-in./DN80/80A	G, N	R	R	R	F, R	F, R	F, R	F, R	R	R
4-in./DN100/100A	G, N	R	R	N/A	F, R	F, R	F	F	R	R
6-in./DN150/150A	N/A	R	R	N/A	F, R	F, R	N/A	N/A	R	R
8-in./DN200/200A	N/A	R	R	N/A	F, R	F, R	N/A	N/A	R	R

- (1) BSPP (G) thread (process connection type code G). N = NPT thread (process connection type code N)
- (2) F = Flat Face (process connection type code F). R = Raised Face (process connection type code R)
- (3) Forged one-piece flange (see [Figure 24](#)).
- (4) Welded construction (see [Figure 24](#)).
- (5) Welded construction for type A flat face; forged one-piece flange for type B1 raised face.

Table 4: Cone Antenna - Alloy C-276 and Alloy 400 (Type vs. Size and Rating)

Process connection size	Process connection rating								
	Thread ⁽¹⁾	ASME B16.5 flanges ⁽²⁾⁽³⁾			EN1092-1 flanges ⁽²⁾⁽⁴⁾⁽⁶⁾			JIS B2220 flanges ⁽²⁾⁽⁶⁾	
		Class 150	Class 300	Class 600	PN16	PN40	PN63	10K	20K
1½-in.	N	N/A	N/A	N/A	N/A	N/A	N/A	N/A	N/A
2-in./ DN50/50A	N	R ⁽⁵⁾	R ⁽⁵⁾	R ⁽⁵⁾	R	R	R	R	R
3-in./ DN80/80A	N/A	R ⁽⁵⁾	R ⁽⁵⁾	R ⁽⁵⁾	R	R	R	R	R
4-in./ DN100/100A	N/A	R ⁽⁵⁾	R ⁽⁵⁾	N/A	R	R	R	R	R
6-in./ DN150/150A	N/A	R ⁽⁵⁾	R ⁽⁶⁾	N/A	R	R	N/A	R	R
8-in./ DN200/200A	N/A	R ⁽⁶⁾	N/A	N/A	R	R	N/A	R	R

- (1) N = NPT thread (process connection type code N)
- (2) R = Raised Face (process connection type code R)
- (3) Welded construction for materials of construction codes H and M (see [Figure 24](#)).
- (4) Backing flange in flat face.
- (5) Available with materials of construction codes 2, 3, H, and M.
- (6) Only available with protective plate design (materials of construction codes 2 and 3).

Table 5: Process Seal Antenna (Type vs. Size and Rating)

Process connection size	Process connection rating						
	Tri-Clamp ⁽¹⁾	ASME B16.5 flanges ⁽²⁾⁽³⁾		EN1092-1 flanges ⁽²⁾⁽³⁾			JIS B2220 flanges ⁽²⁾⁽³⁾
		Class 150	Class 300	PN6	PN16	PN40	10K
2-in./ DN50/50A	C	R	R	R	R	R	R
3-in./ DN80/80A	C	R	R	R	R	R	R
4-in./ DN100/100A	N/A	R	R	R	R	R	R

- (1) C = Tri-Clamp (process connection type code C)
- (2) Forged one-piece flange (see [Figure 24](#)).
- (3) R = Raised Face (process connection type code R)

Table 6: Parabolic Antenna (Type vs. Size and Rating)

Process connection size	Process connection rating				
	Thread ⁽¹⁾	Welded ⁽²⁾	ASME B16.5 Class 150 flange ⁽³⁾	EN1092-1 PN6 flange ⁽⁴⁾	JIS B2220 5K flange ⁽³⁾
3½-in.	G	W	N/A	N/A	N/A
8-in./DN200/200A	N/A	N/A	R	F	R
10-in./DN250/250A	N/A	N/A	R	F	R

- (1) G = BSPP (G) thread (process connection type code G)
- (2) W = Welded connection (process connection type code W)
- (3) R = Raised Face face (process connection type code R)
- (4) F = Flat Face face (process connection type code F)

Accessories

Table 7: Accessories

HART modem and cable	
03300-7004-0002	MACTek® VIATOR® HART modem and cables (USB connection)

Specifications

Performance specifications

General

Conformance to specification ($\pm 3\sigma$ [Sigma])

Technology leadership, advanced manufacturing techniques, and statistical process control ensure specification conformance to at least $\pm 3\sigma$.

Reference conditions

- Measurement target: Metal plate, no disturbing objects
- Temperature: 68 to 86 °F (20 to 30 °C)
- Ambient pressure: 14 to 15 psi (960 to 1060 mbar)
- Relative humidity: 25-75%
- Damping: Default value, 2 s

Instrument accuracy (under reference conditions)

± 0.08 in. (2 mm) ⁽¹⁾

(1) Refers to inaccuracy according to IEC 60770-1 when excluding installation dependent offset. See the IEC 60770-1 standard for a definition of radar specific performance parameters and if applicable corresponding test procedures.

Repeatability

±0.04 in. (±1 mm)

Ambient temperature effect

±0.04 in. (±1 mm)/10 K⁽²⁾

Sensor update rate

Minimum 1 update per second

Maximum level rate

40 mm/s as default, adjustable up to 200 mm/s

Measuring range**Maximum measuring range**

Rosemount 5408: 130 ft. (40 m)

Rosemount 5408:SIS: 130 ft. (40 m) in Control/Monitoring mode⁽³⁾
82 ft. (25 m) in Safety (SIS) mode⁽³⁾

Note that a combination of adverse process conditions, such as heavy turbulence, foam, and condensation, together with products with poor reflection may affect the measuring range.

Accuracy over measuring range

The measuring range is limited by the blind zone at the very top of the tank. In the blind zone, the accuracy exceeds ±0.20 in. (±5 mm) and measurements may not be possible. Measurements close to the blind zone will have reduced accuracy (see [Figure 2](#)).

For the extended cone antennas, the reduced accuracy zone ends 11.8 in. (30 cm) below the antenna end.

(2) Ambient temperature effect specification valid over temperature range -40 °F to 176 °F (-40 °C to 80 °C).

(3) The Rosemount 5408:SIS has two operational modes: Safety (SIS) and Control/Monitoring. Safety (SIS) mode must be set when used in Safety Instrumented Systems. Control/Monitoring mode is intended for use in a Basic Process Control System (BPCS).

Figure 2: Accuracy Over Measuring Range

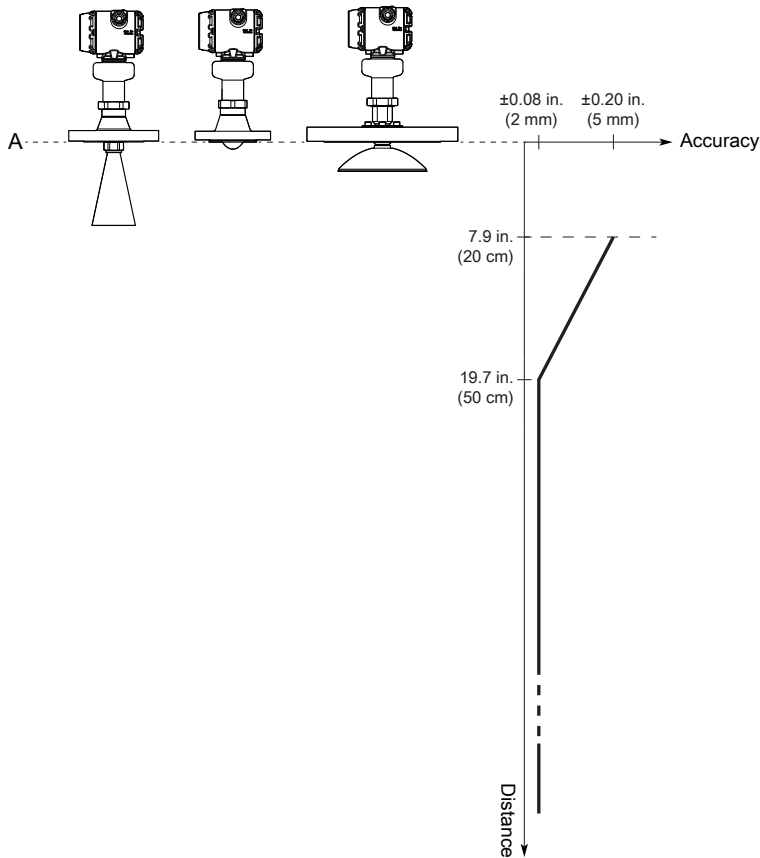

A. Device Reference Point

Table 8: Recommended Measuring Range for Solids, ft. (m)

Antenna	Light powder ⁽¹⁾	Heavy powder ⁽²⁾	Grain size products ⁽³⁾	Larger particles ⁽⁴⁾
2-in. (DN50) cone/process seal	N/A ⁽⁵⁾	33 (10)	33 (10)	39 (12)
3-in. (DN80) cone/process seal	10 (3)	49 (15)	49 (15)	59 (18)
4-in. (DN100) process seal				
4-in. (DN100) cone	23 (7)	66 (20)	130 (40)	130 (40)
8-in. (DN200) parabolic	46 (14)	115 (35)	130 (40)	130 (40)

- (1) Plastic powder/granules/pellets (Dielectric constant: 1.2-2.0)
- (2) Lime powder, cement, sand, etc. (Dielectric constant: 1.5-2.5)
- (3) Grain, kernels, brans, etc. (Dielectric constant: 1.5-4.0)
- (4) Wood chips, pellets, etc. (Dielectric constant: 1.7- 4.5)
- (5) Consider using the Rosemount 5303.

The figures given in [Table 8](#) should be considered as guidelines; the total measuring range may differ depending on other contributing application conditions such as product filling, how the product piles up, silo diameter vs. angle of repose, internal obstacles within the silo, etc.

Beam width and beam angle

The transmitter should be mounted with as few internal structures as possible within the signal beam. Refer to [Table 9](#) for beam angle and [Table 10](#) for beam width at different distances.

Figure 3: Beam Angle and Beam Width

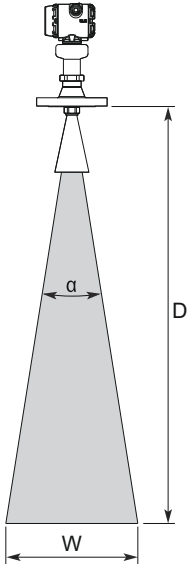

Table 9: Beam Angle

Antenna size	Beam angle (α)
2-in. (DN50) cone/process seal	18°
3-in. (DN80) cone/process seal	14°
4-in. (DN100) cone/process seal	10°
8-in. (DN200) parabolic	4.5°

Table 10: Beam Width, ft. (m)

Distance (D)	Beam width (W)			
	2-in. cone/ process seal	3-in. cone/ process seal	4-in. cone/ process seal	Parabolic
16 (5)	5.2 (1.6)	4.0 (1.2)	2.9 (0.9)	1.3 (0.4)
33 (10)	10.4 (3.2)	8.1 (2.5)	5.7 (1.8)	2.6 (0.8)
49 (15)	15.6 (4.8)	12.1 (3.7)	8.6 (2.6)	3.9 (1.2)
66 (20)	20.8 (6.3)	16.1 (4.9)	11.5 (3.5)	5.2 (1.6)
82 (25)	26.0 (7.9)	20.1 (6.1)	14.3 (4.4)	6.4 (2.0)
98 (30)	31.2 (9.5)	24.2 (7.4)	17.2 (5.3)	7.7 (2.4)
131 (40)	41.6 (12.7)	32.2 (9.8)	23.0 (7.0)	10.3 (3.1)

Environment

Vibration resistance

- 2 g at 10-180 Hz according to IEC 61298-3, level “field with general application”
- IACS UR E10 test 7

For compliance with these standards, the transmitter housing must be fully engaged into the sensor module. This is achieved by rotating the transmitter housing clockwise to thread limit. For further details, see the Rosemount 5408 and 5408:SIS [Reference Manual](#).

Electromagnetic compatibility (EMC)

- EMC Directive (2014/30/EU): EN 61326-1
- EN 61326-2-3
- NAMUR recommendations NE21⁽⁴⁾

For Rosemount 5408:SIS and Rosemount 5408 with option code EF1, the blue plug on the terminal block must be connected.

Pressure Equipment Directive (PED)

Complies with 2014/68/EU article 4.3

Built-in lightning protection

EN 61326, IEC 61000-4-5, level 6kV

Radio approvals

- Radio Equipment Directive (2014/53/EU): ETSI EN 302 372, ETSI EN 302 729 and EN 62479
- Part 15 of the FCC Rules
- Industry Canada RSS 211

Functional specifications

General

Field of application

Continuous level measurements for tank monitoring, process control, and overflow prevention on a broad range of liquids, slurries, and solids.

Ideal for applications with varying and harsh process conditions, such as heavy turbulence, foaming, product build-up, condensing vapors, sticky, viscous, corrosive, and crystallizing products.

Measurement principle

Frequency Modulated Continuous Wave (FMCW)

Frequency range

24.05 to 27.0 (26.5⁽⁵⁾) GHz

(4) In challenging applications where the dynamic of the Rosemount 5408 and 5408:SIS sensitivity is utilized by multiple factors such as small aperture antenna, very low product dielectric constant and/or turbulent surface, the margin for additional influence due to extreme EMC may be limited.

(5) 26.5 GHz in Australia and New Zealand, and for LPR (Level Probing Radar), option code OA.

Maximum output power

-5 dBm (0.32 mW)

Internal power consumption

< 1 W in normal operation

Humidity

0 - 100% relative humidity, non-condensing

Turn-on time

< 40 s ⁽⁶⁾

Functional safety

Safety Instrumented System (SIS) certification

The Rosemount 5408:SIS Level Transmitter is IEC 61508 certified accordingly:

- Low and high demand: Type B element
- SIL 2 for random integrity @ HFT=0
- SIL 3 for random integrity @ HFT=1
- SIL 3 for systematic capability

Safety deviation

±2.0% of analog output span

Transmitter response time

- < 6 s at damping value 2 s (default)⁽⁷⁾
- < 2 s at damping value 0 s (minimum)⁽⁷⁾

The transmitter response time will be a function of the configured Damping value. Rosemount Radar Master Plus has a built-in function to calculate the transmitter’s measurement response time (requires option code EF2).

Failure rates

Table 11: Failure Rates According to IEC 61508 in FIT (Failure In Time per billion hours)

λ_{SD}	λ_{SU}	λ_{DD}	λ_{DU}	SFF
0	260	737	79	92.7%

(6) Time from when power is applied to the transmitter until performance is within specifications.

(7) Step response time as per IEC 61298-2.

Proof-testing

Table 12: Suggested Proof-tests

Proof-test	Proof-test coverage	Remaining dangerous, undetected failures
1-point level and analog output verification	73%	21 FIT
2-point level and analog output verification	84%	13 FIT
Analog output verification	33%	53 FIT
Level deviation monitoring	61%	31 FIT

Failure rate data

The [FMEDA report](#) includes failure rate data, assessment details, and assumptions regarding failure rate analysis.

Display and configuration

LCD display (option code M5)

- Toggles between selected output variables
- Shows diagnostic information (alerts)

Figure 4: LCD Display

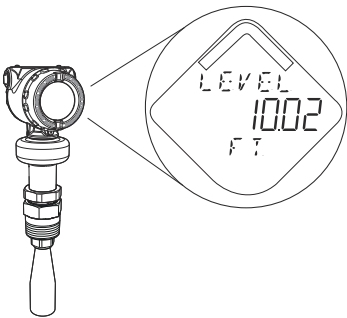

Remote display

Data can be read remotely by using the Rosemount 751 Field Signal Indicator, see the corresponding [Product Data Sheet](#) for more information.

Configuration tools

- Rosemount Radar Master Plus for Rosemount 5408 Series (accessible through any Field Device Integration (FDI) based tool, e.g. Instrument Inspector™ Application ⁽⁸⁾)
- Device Descriptor (DD) based systems, e.g. AMS Device Manager, 475 Field Communicator, AMS Trex™ Device Communicator, and DeltaV™, or any other EDDL or enhanced-EDDL host
- Field Device Integration (FDI) based systems

Damping

User selectable (default is 2 s, minimum is 0 s) ⁽⁹⁾

⁽⁸⁾ Included in delivery of the transmitter. For additional information, visit Emerson.com/RosemountRadarMasterPlus.

⁽⁹⁾ The Damping parameter defines how fast the device responds to level changes (step response). A high value makes the level steady but the device reacts slowly to level changes in the tank.

Output units

- Level and distance: ft., in., m, cm, mm
- Level rate: ft/s, in./min, in./s, m/h, m/s
- Volume: ft³, in.³, yd³, US gal, imperial gal, barrel (bbl), m³, l
- Temperature: °F, °C
- Signal strength: mV

Table 13: Output Variables

Variable	4-20 mA	Digital output	LCD display
Level	✓	✓	✓
Distance (Ullage)	✓	✓	✓
Volume	✓	✓	✓
Scaled Variable ⁽¹⁾	✓	✓	✓
Electronics Temperature	N/A	✓	✓
Signal Quality ⁽¹⁾	N/A	✓	✓
Level Rate	N/A	✓	✓
Signal strength	N/A	✓	✓
Percent of Range	N/A	✓	✓
Percent of Range Auxiliary	N/A	✓	✓
User Defined ⁽¹⁾	✓	✓	✓

(1) Only for transmitters ordered with Smart Diagnostics Suite (option code DA1).

4-20 mA HART

Output

Two-wire, 4-20 mA. Digital process variable is superimposed on 4-20 mA signal, and available to any host that conforms to the HART protocol. The digital HART[®] signal can be used in multidrop mode.

HART Revision

- Revision 6 (default)
- Revision 7 (option code HR7)

The HART revision can be switched in field.

Power supply

Transmitter operates on 12-42.4 Vdc transmitter terminal voltage (12-30 Vdc in Intrinsically Safe installations).

Power consumption

Max. 1 W, current max. 23 mA

Load limitations

For HART[®] communication, a minimum loop resistance of 250 Ω is required. Maximum loop resistance is determined by the voltage level of the external power supply.

Figure 5: Load Limits

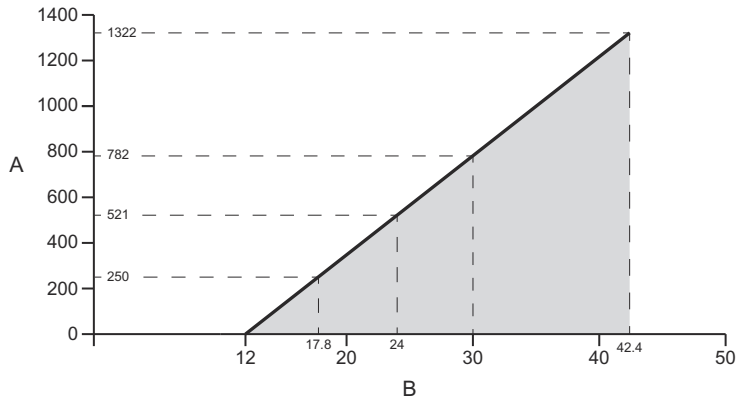

Maximum Loop Resistance = 43.5 * (External Power Supply Voltage - 12)

A. Loop Resistance (Ohms)

B. External Power Supply Voltage (Vdc)

Cable selection

Use 24-14 AWG wire. Twisted pairs and shielded wiring are recommended for environments with high EMI (electromagnetic interference).

Analog signal on alarm

The transmitter automatically and continuously performs self-diagnostic routines. If a failure or a measurement error is detected, the analog signal will be driven offscale to alert the user. High or low failure mode is user-configurable.

Table 14: Signal on Alarm

Standard	High	Low
Rosemount standard	≥ 21.75 mA (default)	≤ 3.75 mA (option code C8)
NAMUR NE43	≥ 22.50 mA (option code C4)	≤ 3.6 mA (option code C5)

Analog saturation levels

The transmitter will drive the output to high or low saturation values if measurement goes outside the 4-20 mA range values.

Table 15: Saturation Levels

Standard	High	Low
Rosemount standard (default and option code C8)	20.8 mA	3.9 mA
NAMUR NE43 (option code C4 and C5)	20.5 mA	3.8 mA

Diagnostics

Alerts

The Rosemount 5408 and 5408:SIS are compliant with NAMUR NE 107 Field Diagnostics for standardized device diagnostic information.

Tools and logging in Rosemount Radar Master Plus

- Echo curve
- Measurement and alert log

Rosemount Radar Master Plus, embedded in Instrument Inspector, enables easy and powerful troubleshooting with the echo curve tool as well as the measurement and alert log.

The measurement and alert log holds records of the last seven days of level readings and echo curve profiles, as well as the 50 last alert events. The logs can be transferred from the transmitter’s internal memory to a local computer and be presented in a graphical time line, enabling analysis of historical behaviors.

Smart Diagnostics Suite (option code DA1)

- Signal Quality Metrics** Diagnostics package that monitors the relations between surface, noise, and threshold. The function can be used to detect abnormal conditions in the process such as antenna contamination or sudden loss of signal strength. Signal Quality is available as output variable and it comes with user configurable alerts.
- Power Advisory** The transmitter automatically measures and monitors the input voltage. If the voltage is too low, operators will be provided with an early alert.
- Scaled Variable** The scaled variable configuration allows the user to convert a transmitter variable into an alternative measurement, such as flow, mass, or calibrated level (e.g. 5 point verification).
- User Defined Variable** Allows designating more than 200 variables in the device as output variable.

Process temperature and pressure rating

The following figures give the maximum process temperature (measured at the lower part of the flange, Tri-Clamp, or threaded connection) and pressure rating for different antenna types.

Final rating may be lower depending on flange selection.

For antenna type code CAB, at 100 °F (38 °C), the rating decreases with increasing temperature per ASME B16.5 Table 2-2.2, Class 300.

Figure 6: Cone Antenna (PTFE Seal)

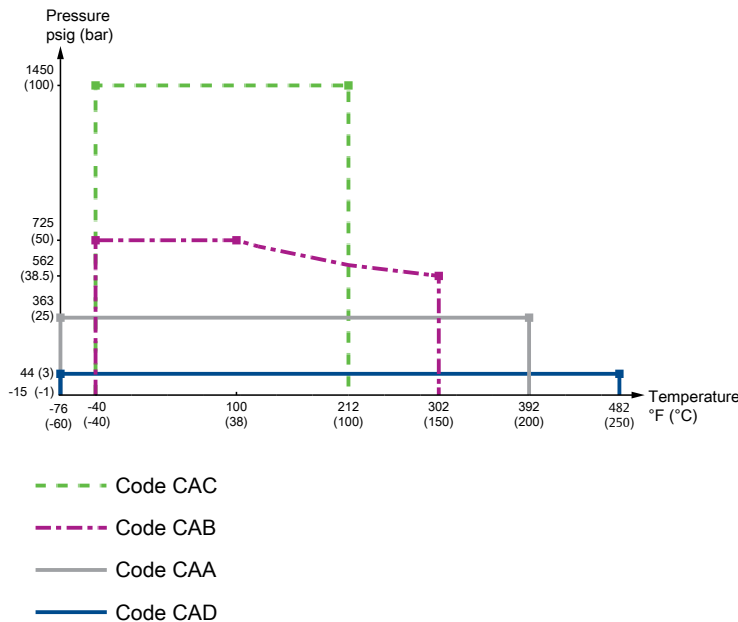

Figure 7: Cone Antenna (PEEK Seal)

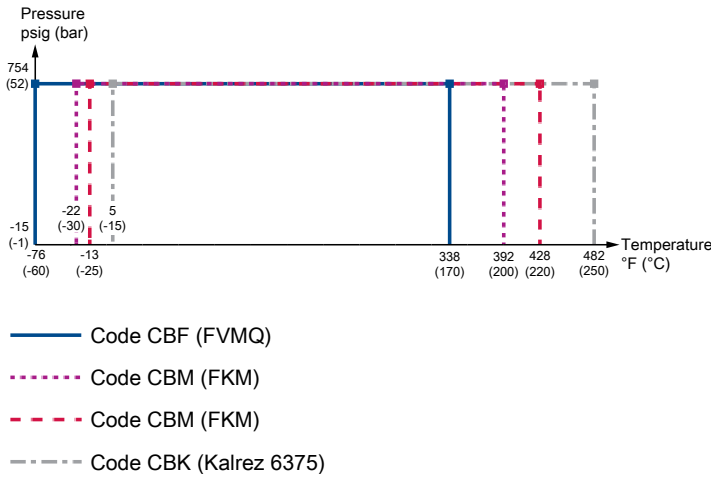

Figure 8: Process Seal Antenna

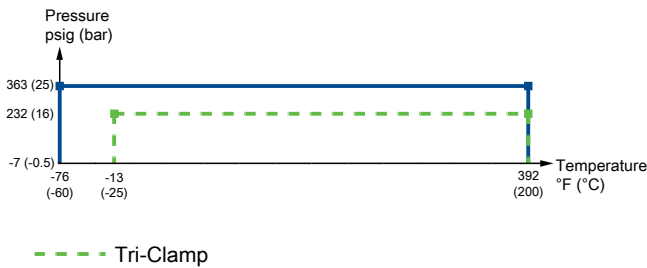

Figure 9: Parabolic Antenna



Temperature limits

Verify that the operating atmosphere of the transmitter is consistent with the appropriate hazardous locations certifications, see [Product Certifications](#).

Table 16: Ambient Temperature Limits

Description	Operating limit	Storage limit ⁽¹⁾
Without LCD display	-40 °F to 176 °F (-40 °C to 80 °C)	-58 °F to 176 °F (-50 °C to 80 °C)
With LCD display ⁽²⁾		-40 °F to 176 °F (-40 °C to 80 °C)

(1) The minimum storage temperature is -22 °F (-30 °C) for the cone antenna with Kalrez 6375 O-ring (antenna type code CBK).

(2) LCD display may not be readable and LCD display updates will be slower at temperatures below -4 °F (-20 °C).

The ambient temperature limits may be further restricted by the process temperature as described by [Figure 10](#).

Figure 10: Ambient Temperature vs. Process Temperature

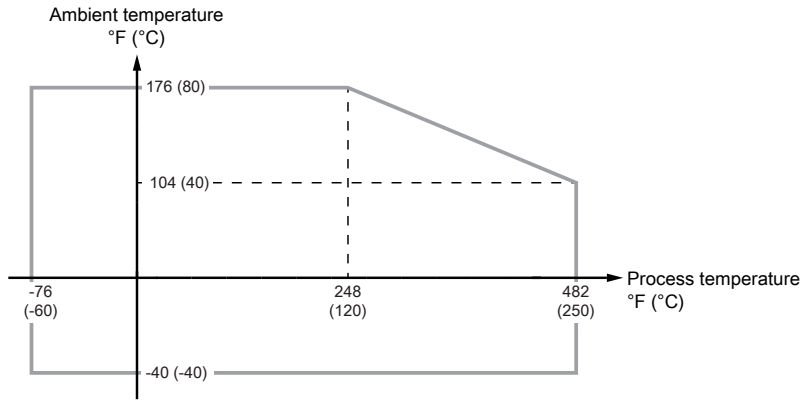

Flange rating

ASME

- 316 SST according to ASME B16.5 Table 2-2.2
- 316L SST according to ASME B16.5 Table 2-2.3 (for protective plate design)⁽¹⁰⁾
- Alloy C-276 (UNS N10276) according to ASME B16.5 Table 2-3.8
- Alloy 400 (UNS N04400) according to ASME B16.5 Table 2-3.4

EN

- 1.4404 according to EN 1092-1 material group 13E0

JIS

- 316 SST according to JIS B2220 material group No. 2.2
- 316L SST according to JIS B2220 material group No. 2.3 (for protective plate design)⁽¹⁰⁾

Conditions used for flange strength calculations

Table 17: 316/316L SST (EN 1.4404) Flanges

Item	ASME	EN, JIS
Bolting material	SA193 B8M CL.2, SA193 B7 ⁽¹⁾ , or SA320 L7 ⁽¹⁾	EN 1515-1/2, ISO 3506 A4-70, or Bumax [®] 88 ⁽¹⁾
Gasket ⁽²⁾	Soft (1a) with min. thickness 1.6 mm or Spiral wound gasket with nonmetallic filler (1b)	Soft (EN 1514-1) with min. thickness 1.6 mm or Spiral wound gasket with nonmetallic filler (EN 1514-2)
Flange material	Stainless steel A182 Gr. F316 and EN 10222-5-1.4404	
Hub material ⁽³⁾	Stainless steel SA479 316 and EN 10272-1.4404	

(1) Only applicable to forged one-piece flanges.
 (2) Not applicable to process seal antenna (features an integrated gasket).
 (3) Only applicable to flanges with welded construction per Table 3.

(10) Flange rating according to backing flange.

Table 18: Flanges with Protective Plate Design

Item	ASME	EN, JIS
Bolting material	SA193 B8M Cl.2	EN 1515-1/2, ISO 3506 A4-70
Gasket ⁽¹⁾	Soft (1a) with min. thickness 1.6 mm or Spiral wound gasket with nonmetallic filler (1b)	Soft (EN 1514-1) with min. thickness 1.6 mm or Spiral wound gasket with nonmetallic filler (EN 1514-2)
Flange material	Stainless steel A182 Gr. F316L/F316 and EN 10222-5-1.4404	
Hub material	SB574 Gr. N10276 (solution annealed condition) or SB164 Gr. N04400 (solution annealed condition)	

(1) Note that a minimum gasket thickness of 0.125 in. (3.2 mm) is required when using an air purge ring (option code PC1).

Table 19: Alloy C-276 (UNS N10276) Flanges

Item	ASME	EN, JIS
Bolting material	UNS N10276	UNS N10276
Gasket	Soft (1a) with min. thickness 1.6 mm or Spiral wound gasket with nonmetallic filler (1b)	Soft (EN 1514-1) with min. thickness 1.6 mm or Spiral wound gasket with nonmetallic filler (EN 1514-2)
Flange material	SB462 Gr. N10276 (solution annealed condition) or SB575 Gr. N10276 (solution annealed condition)	
Hub material	SB574 Gr. N10276 (solution annealed condition)	

Table 20: Alloy 400 (UNS N04400) Flanges

Item	ASME	EN, JIS
Bolting material	UNS N04400	UNS N04400
Gasket	Soft (1a) with min. thickness 1.6 mm or Spiral wound gasket with nonmetallic filler (1b)	Soft (EN 1514-1) with min. thickness 1.6 mm or Spiral wound gasket with nonmetallic filler (EN 1514-2)
Flange material	SB/B564 Gr. N04400 (solution annealed condition) or SB/B127 Gr. N04400 (solution annealed condition)	
Hub material	SB164 Gr. N04400 (solution annealed condition)	

Air purging

An air purge connection can prevent clogging of the antenna in extreme applications with dirt or heavy coating. The easiest way to determine if air purging is needed, is to inspect the tank internal conditions at the location intended for the transmitter. If there is normally a thick layer of product build-up there, air purging is most likely needed. Typical purging media to use is air.

All parabolic antennas come with an integrated air purge connection (see [Figure 11](#)).

Figure 11: Air Purging for Parabolic Antenna

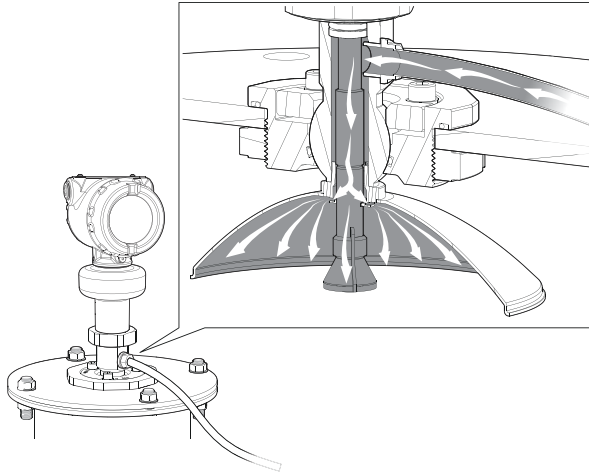

An air purge connection is also available for cone antennas with flanged connection by selecting option code PC1. This option consists of an antenna with purge holes and a separate air purge ring (see [Figure 12](#)).

Figure 12: Air Purging for Cone Antenna

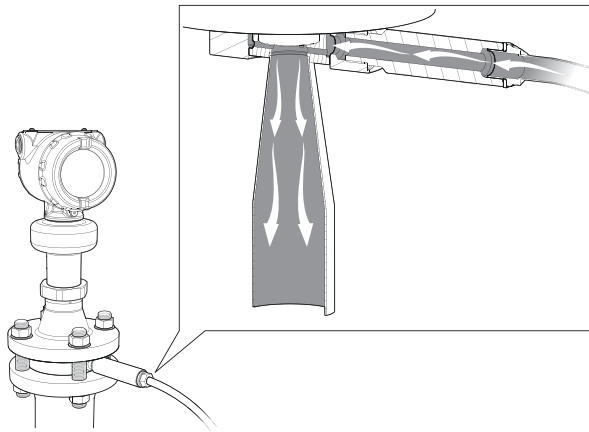

Incoming air supply specification

- Maximum pressure: 190 psi (13 bar)
- Recommended pressure: 100 to 115 psi (7 to 8 bar)
- Inlet/outlet connection: BSPP (G) 3/8-in.
- Air consumption: 252 gal/min at 65 psi (955 l/min at 4.5 bar)

System integration

Rosemount 333 HART Tri-Loop™

By sending the digital HART signal to the optional HART Tri-Loop, it is possible to have up to three additional 4–20 mA analog signals.



See the Rosemount 333 HART Tri-Loop [Product Data Sheet](#) for additional information.

Emerson™ Wireless 775 THUM™ Adapter

The optional Emerson Wireless 775 THUM Adapter can be mounted directly on the transmitter or by using a remote mounting kit.



IEC 62591 (*WirelessHART*®) enables access to multivariable data and diagnostics, and adds wireless to almost any measurement point.

See the Emerson Wireless 775 THUM Adapter [Product Data Sheet](#) and [Technical Note](#) for additional information.

Physical specifications

Material selection

Emerson provides a variety of Rosemount products with various product options and configurations including materials of construction that can be expected to perform well in a wide range of applications. The Rosemount product information presented is intended as a guide for the purchaser to make an appropriate selection for the application. It is the purchaser's sole responsibility to make a careful analysis of all process parameters (such as all chemical components, temperature, pressure, flow rate, abrasives, contaminants, etc.), when specifying product, materials, options and components for the particular application. Emerson is not in a position to evaluate or guarantee the compatibility of the process fluid or other process parameters with the product, options, configuration or materials of construction selected.

Engineered solutions

When standard model codes are not sufficient to fulfill requirements, please consult the factory to explore possible Engineered Solutions. This is typically, but not exclusively, related to the choice of wetted materials or the design of a process connection. These Engineered Solutions are part of the expanded offerings and may be subject to additional delivery lead time. For ordering, factory will supply a special P-labeled numeric option code that should be added at the end of the standard model string.

Housing and enclosure

Electrical connections

Two cable/conduit entries ($\frac{1}{2}$ -14 NPT, M20 x 1.5, or G $\frac{1}{2}$)

Optional adapters: M12 4-pin male eurofast connector or A size Mini 4-pin male minifast connector

Materials

- Electronics housing: Polyurethane-covered Aluminum or Stainless Steel Grade CF-8M (ASTM A743)

- Sensor module: 316L SST

Weight

- Aluminum housing: 6.2 lb (2.8 kg)⁽¹¹⁾
- Stainless steel housing: 10.0 lb (4.5 kg)⁽¹¹⁾

Ingress protection

IP 66/67/68⁽¹²⁾ and NEMA[®] 4X

Tank connection

The tank connection consists of a tank seal, a flange, NPT or BSPP (G) threads, Tri Clamp, or a specific welded connection with swivel feature for parabolic antenna.

Flange dimensions

Follows ASME B16.5, JIS B2220, and EN 1092-1 standards. For more information, see [Standard flanges](#).

Antenna versions

Cone antenna

- Best choice for most applications, including closed vessels, still pipe/chamber installations, and open air applications
- Extended cone antennas are available for tall nozzles (option code S1 and S2). Depending on measurement conditions, a reduction of sensitivity close to antenna end might be present.

Process seal antenna

- All PTFE wetted parts ideal for use in corrosive and hygienic applications
- Suitable for applications with heavy condensation/build-up

Parabolic antenna

- Alternative for long measuring ranges in combination with conditions such as low reflective media
- Suitable for a broad range of solid materials (may need air purging in dusty environments)

Material exposed to tank atmosphere

Cone antenna, PTFE seal

- 316/316L SST (EN 1.4404), Alloy C-276 (UNS N10276), or Alloy 400 (UNS N04400)
- PTFE fluoropolymer

Cone antenna, PEEK seal

- 316/316L SST (EN 1.4404), Alloy C-276 (UNS N10276), or Alloy 400 (UNS N04400)
- PEEK polyetheretherketone with PTFE fluoropolymer filler
- FVMQ fluorosilicone, Kalrez 6375 perfluoroelastomer, FKM fluoroelastomer, or Viton fluoroelastomer (O-ring)

(11) Fully functional transmitter with sensor module, housing, terminal block, LCD display, and covers

(12) The transmitter meets IP 68 at 9.8 ft. (3 m) for 30 minutes.

Process seal antenna

- PTFE fluoropolymer

Parabolic antenna

- 316/316L SST (EN 1.4404)
- PTFE fluoropolymer
- FVMQ fluorosilicone (O-ring)

Installation and mounting considerations

Tank installations

- For optimal performance, the transmitter should be installed in locations with a clear and unobstructed view of the product surface.
- The transmitter should be mounted with as few internal structures as possible within the signal beam, see [Beam width and beam angle](#).
- Do not install the transmitter in the center of the tank.
- Do not mount close to or above the inlet stream.
- Multiple Rosemount 5408 and 5408:SIS Level Transmitters can be used in the same tank without interfering with each other.

Table 21: Distance to Tank Wall (L)

Application	Minimum	Recommended
Liquids	8 in. (200 mm)	1/2 of tank radius
Solids	8 in. (200 mm)	2/3 of tank radius

Figure 13: Recommended Mounting Position

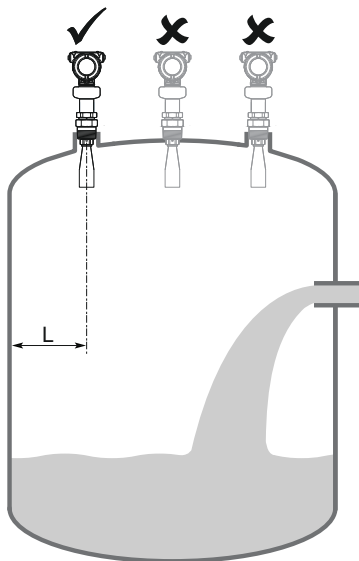

Non-metallic tanks

The walls in non-metallic tanks can be invisible to the radar signal, so nearby objects outside the tank may cause disturbing radar echoes. Wherever possible, the transmitter should be positioned so that objects close to the tank are kept outside the signal beam.

Antenna size

Choose as large antenna diameter as possible. A larger antenna diameter concentrates the radar beam, will be less susceptible to obstruction interference, and assures maximum antenna gain.

Antenna inclination

Ensure the antenna is aligned perpendicular to the product surface (see *Figure 14*). The parabolic antenna comes with a swivel connection that adjusts for angled tank roofs.

Note that if the surface echo is weak in solids applications, then a small inclination of the parabolic antenna toward the surface slope may improve the performance.

Figure 14: Inclination

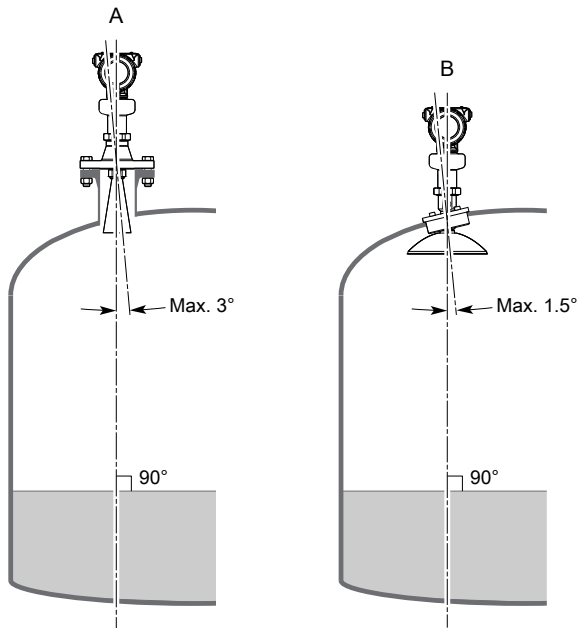

- A. Cone antenna/process seal antenna
- B. Parabolic antenna

Nozzle requirements for cone antenna

For best performance, the cone antenna should extend at least 0.4 in. (10 mm) below the nozzle. If required, use the extended cone antenna versions (option code S1 or S2).

However, the antenna can be recessed in smooth nozzles up to 4 ft. (1.2 m). Note that if the inside of the nozzle has irregularities (e.g. due to bad welding, rust, or deposit), then use the extend cone antenna.

Figure 15: Mounting of the Cone Antenna

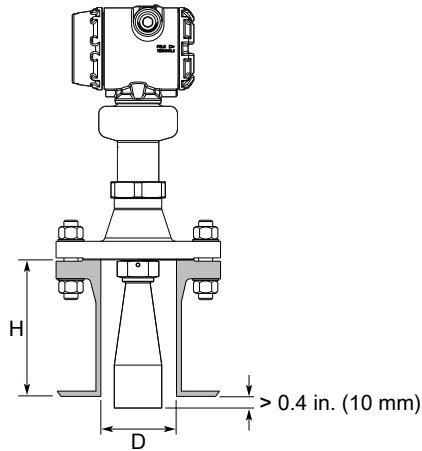

Table 22: Nozzle Requirements for Cone Antenna, in Inches (Millimeters)

Antenna size	Minimum nozzle diameter (D) ⁽¹⁾	Recommended maximum nozzle height (H) ⁽²⁾⁽³⁾	
		Antenna	Antenna with air purge ring (code PC1)
2-in. (DN50)	1.94 (49.3)	5.71 (145)	4.69 (119)
3-in. (DN80)	2.80 (71.0)	5.63 (143)	4.61 (117)
4-in. (DN100)	3.78 (96.0)	6.54 (166)	5.51 (140)

- (1) The antennas are sized to fit within schedule 80 or lower schedules.
- (2) The values are valid for cone antennas without antenna extension.
- (3) For liquid applications, the cone antenna can be recessed in smooth nozzles up to 4 ft. (1.2 m), but note that the accuracy may be reduced in the region close to the nozzle.

Nozzle requirements for process seal antenna

The antenna can be used on nozzles up to 4 ft. (1.2 m). Disturbing objects inside the nozzle may impact the measurement, and should therefore be avoided.

Figure 16: Mounting of the Process Seal Antenna

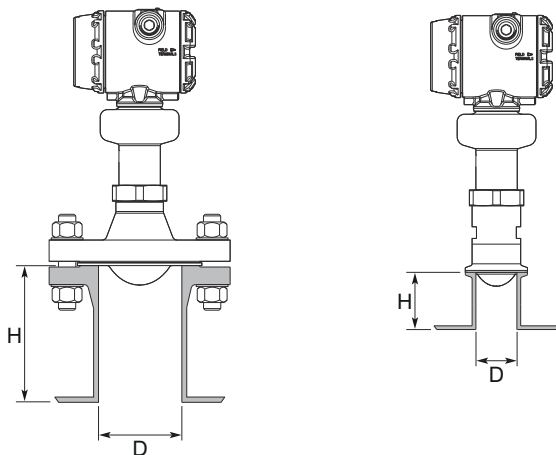

Table 23: Nozzle Requirements for Process Seal Antenna

Antenna size	Minimum nozzle diameter (D) ⁽¹⁾	Recommended maximum nozzle height (H) ⁽²⁾
2-in. (DN50)	1.77 in. (45 mm)	4 ft. (1.2 m)
3-in. (DN80)	2.76 in. (70 mm)	4 ft. (1.2 m)
4-in. (DN100)	2.76 in. (70 mm)	4 ft. (1.2 m)

(1) The antennas are sized to fit within schedule 120 or lower schedules.

(2) For hygienic applications, the nozzle height (H) must not exceed 2 × nozzle diameter (D) to ensure cleanability. Maximum nozzle height is 5 in. (127 mm).

Nozzle requirements for parabolic antenna

See [Table 24](#) for nozzle height recommendations at different inclination angle.

Figure 17: Mounting of the Parabolic Antenna

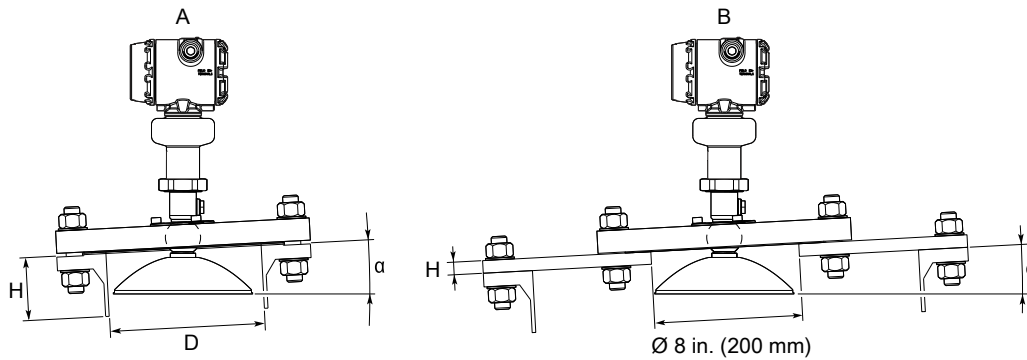

- A. Nozzle mounting
- B. Flange mounting in manhole cover

Table 24: Nozzle Requirements for Parabolic Antenna, in Inches (Millimeters)

Nozzle size (D)	Inclination angle (α)	Maximum nozzle height (H) ⁽¹⁾
Pipe schedule std, Ø 8 in. (200 mm)	0°	5.9 (150)
	3°	5.5 (140)
	6°	1.6 (40)
	9°	1.2 (30)
	12°	1.0 (25)
	15°	0.6 (15)
Pipe schedule std, Ø10 in. (250 mm)	0°	8.0 (200)
	3°	8.0 (200)
	6°	8.0 (200)
	9°	8.0 (200)
	12°	5.9 (150)
	15°	4.3 (110)

(1) Note that the inside of the nozzle must be smooth (i.e. avoid bad welding, rust, or deposit).

Still pipe/chamber installations

Installation in still pipe/chamber is recommended for tanks where there are excessive foaming or turbulence. Still pipe/chamber may also be used to avoid disturbing objects in the tank.

Still pipe

Consider the following still pipe requirements:

- Pipe**
 - Pipes should be an all-metal material.
 - Pipe should have a constant inside diameter.
 - The inner surface must be smooth and clear of any rough edges. (Smooth pipe joints are acceptable, but may reduce accuracy.)
 - The end of the pipe must extend beyond the zero level.
- Holes**
 - Maximum hole diameter is 1 in. (25 mm).
 - Minimum distance between holes is 6 in. (150 mm).
 - Holes should be drilled on one side only and deburred.
 - Drill one hole above maximum product surface.
- Antenna**
 - All cone/process seal antenna sizes can be used for still pipe/chamber installations.
 - The gap between the cone antenna and the still pipe should be maximum 0.2 in. (5 mm). If required, order a larger antenna and cut on location. See [Table 35](#) for antenna dimensions.

Figure 18: Still Pipe Requirements

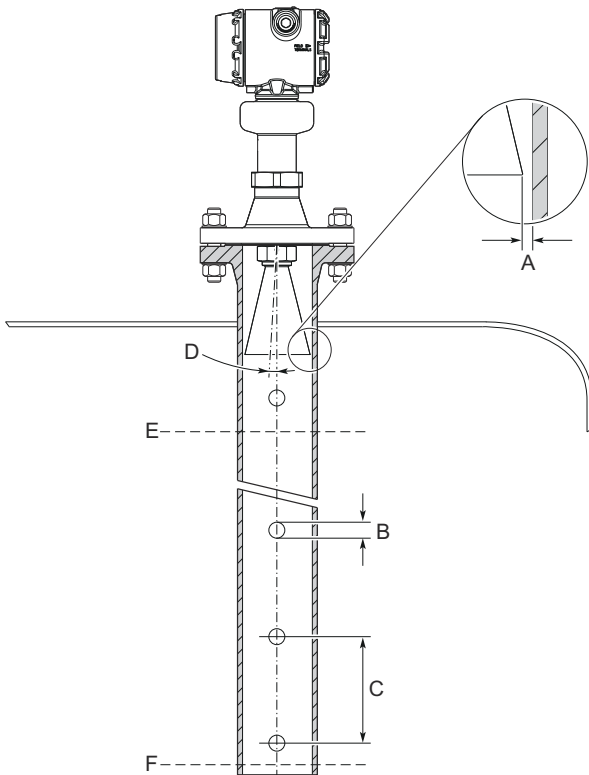

- A. Max. 0.2 in. (5 mm)
- B. Max. 1 in. (25 mm)
- C. Min. 6 in. (150 mm)
- D. Max. 1°
- E. Level = 100%
- F. Level = 0%

Chamber

Consider the following chamber requirements:

- Pipes should be an all-metal material.
- Pipe should have a constant inside diameter.
- Inlet pipes should not protrude into the inside of the stand pipe.
- The inner surface must be smooth and clear of any rough edges. (Smooth pipe joints are acceptable, but may reduce accuracy.)
- The gap between the cone antenna and the stand pipe should be maximum 0.2 in. (5 mm). If required, order a larger antenna and cut on location. See [Table 35](#) for antenna dimensions.

Figure 19: Chamber Requirements

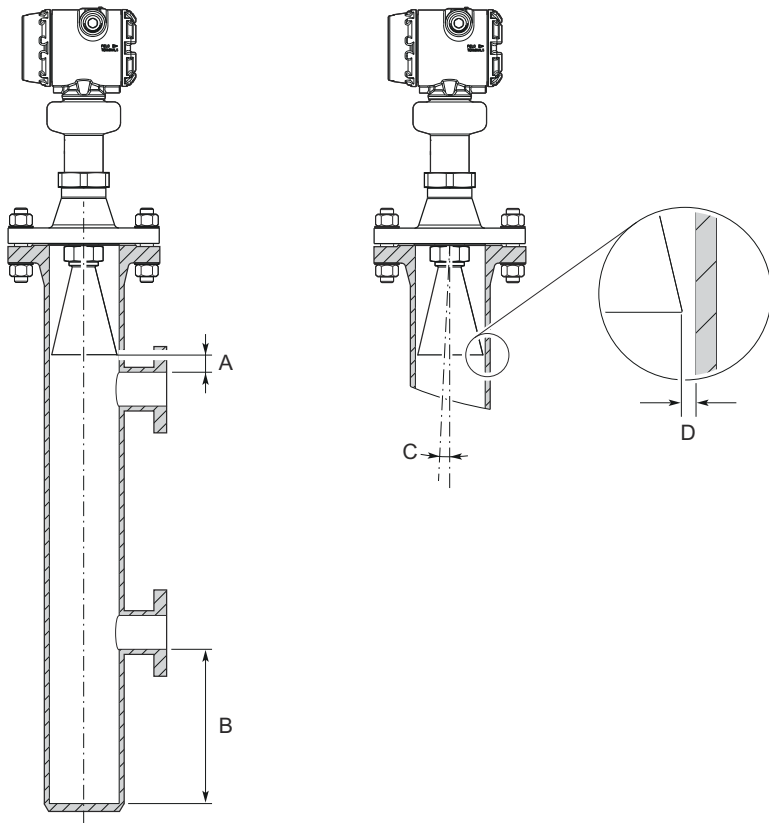

- A. Min. 0.4 in. (10 mm)
- B. Min. 6 in. (150 mm)
- C. Max. 1°
- D. Max. 0.2 in. (5 mm)

For more information and installation requirements, refer to the Guidelines for Choosing and Installing Radar in Stilling Wells and Bypass Chambers [Technical Note](#).

Ball valve installation

The transmitter can be isolated from the process by using a valve:

- Use a full-port ball valve.
- Ensure there is no edge between the ball valve and the nozzle or still pipe, the inside should be smooth.
- Valves can be combined with still pipes.

Product Certifications

Rev 2.3

European directive information

A copy of the EU Declaration of Conformity can be found at the end of the Rosemount™ 5408 and 5408:SIS [Product Certifications](#) document. The most recent revision of the EU Declaration of Conformity can be found at Emerson.com/Rosemount.

Safety Instrumented Systems (SIS)

SIL 3 Capable: IEC 61508 certified for use in safety instrumented systems up to SIL 3 (Minimum requirement of single use (1oo1) for SIL 2 and redundant use (1oo2) for SIL 3).

Telecommunication compliance

Measurement principle

Frequency Modulated Continuous Wave (FMCW), 26 GHz

Maximum output power

-5 dBm (0.32 mW)

Frequency range

24.05 to 27.0⁽¹³⁾ GHz (TLPR)

24.05 to 26.5 GHz (LPR)

LPR (Level Probing Radar) equipment are devices for measurement of level in the open air or in a closed space. Model option “OA”. Hardware Version Identification Number (HVIN) is 5408L.

TLPR (Tank Level Probing Radar) equipment are devices for measurement of level in a closed space only (i.e metallic, concrete or reinforced fiberglass tanks, or similar enclosure structures made of comparable attenuating material). Hardware Version Identification Number (HVIN) is 5408T.

FCC

Note: This equipment has been tested and found to comply with the limits for a Class B digital device, pursuant to part 15 of the FCC Rules. These limits are designed to provide reasonable protection against harmful interference in a residential installation. This equipment generates, uses and can radiate radio frequency energy and, if not installed and used in accordance with the instructions, may cause harmful interference to radio communications. However, there is no guarantee that interference will not occur in a particular installation. If this equipment does cause harmful interference to radio or television reception, which can be determined by turning the equipment off and on, the user is encouraged to try to correct the interference by one or more of the following measures:

- Reorient or relocate the receiving antenna.
- Increase the separation between the equipment and receiver.

(13) 26.5 GHz in Australia and New Zealand.

- Connect the equipment into an outlet on a circuit different from that to which the receiver is connected.
- Consult the dealer or an experienced radio/TV technician for help.

FCC ID: K8C5408L (for LPR)
 K8C5408T (for TLPR)

IC

This device complies with Industry Canada's licence-exempt RSS standard. Operation is subject to the following conditions:

1. This device may not cause interference.
2. This device must accept any interference received, including interference that may cause undesired operation.
3. The installation of the LPR/TLPR device shall be done by trained installers in strict compliance with the manufacturer's instructions.
4. The use of this device is on a "no-interference, no-protection" basis. That is, the user shall accept operations of high-powered radar in the same frequency band which may interfere with or damage this device. However, devices found to interfere with primary licensing operations will be required to be removed at the user's expense.
5. Devices operating under TLPR conditions (i.e. not operating in "Open Air" Mode) shall be installed and operated in a completely enclosed container to prevent RF emissions, which can otherwise interfere with aeronautical navigation.

Le présent appareil est conforme aux CNR d'Industrie Canada applicables aux appareils radio exempts de licence. L'exploitation est autorisée aux conditions suivantes:

1. l'appareil ne doit pas produire de brouillage.
2. l'utilisateur de l'appareil doit accepter tout brouillage radioélectrique subi, même si le brouillage est susceptible d'en compromettre le fonctionnement.
3. L'installation d'un dispositif LPR ou TLPR doit être effectuée par des installateurs qualifiés, en pleine conformité avec les instructions du fabricant.
4. Ce dispositif ne peut être exploité qu'en régime de non-brouillage et de non-protection, c'est-à-dire que l'utilisateur doit accepter que des radars de haute puissance de la même bande de fréquences puissent brouiller ce dispositif ou même l'endommager. D'autre part, les capteurs de niveau qui perturbent une exploitation autorisée par licence de fonctionnement principal doivent être enlevés aux frais de leur utilisateur.
5. Un dispositif visé comme TLPR ("Open Air") doit être installé et exploité dans un réservoir entièrement fermé afin de prévenir les rayonnements RF qui pourraient autrement perturber la navigation aéronautique.

Certificate: 2827A-5408L (for LPR)
 2827A-5408T (for TLPR)

Radio Equipment Directive (RED) 2014/53/EU

This device complies with ETSI EN 302 372 (TLPR), ETSI EN 302 729 (LPR) and EN 62479.

For the receiver test that covers the influence of an interferer signal to the device, the performance criterion has at least the following level of performance according to ETSI TS 103 361 [6].

- Performance criterion: measurement value variation Δd over time during a distance measurement
- Level of performance: $\Delta d \leq \pm 2$ mm

LPR (Level Probing Radar), model code "OA"

Install at a separation distance of >4 km from Radio Astronomy sites, unless a special authorization has been provided by the responsible National regulatory authority (a list of Radio Astronomy sites may be found at www.craf.eu).

Between 4 km to 40 km around any Radio Astronomy site the LPR antenna height shall not exceed 15 m height above ground.

TLPR (Tank Level Probing Radar)

The device must be installed in closed tanks. Install according to requirements in ETSI EN 302 372 (Annex E).

Installing equipment in North America

The US National Electrical Code[®] (NEC) and the Canadian Electrical Code (CEC) permit the use of Division marked equipment in Zones and Zone marked equipment in Divisions. The markings must be suitable for the area classification, gas, and temperature class. This information is clearly defined in the respective codes.

U.S.A.

E5 Explosionproof (XP), Dust-Ignitionproof (DIP)

Certificate: FM-US FM16US0010X

Standards: FM Class 3600 – 2011; FM Class 3615 – 2006; FM Class 3810 – 2005; ANSI/ISA 60079-0 – 2013; ANSI/UL 60079-1 – 2015; ANSI/ISA 60079-26 – 2011; ANSI/ISA 60079-31 – 2015; ANSI/NEMA[®] 250 – 1991; ANSI/IEC 60529 – 2004, ANSI/ISA 12.27.01:2011

Markings: XP CL I, DIV 1, GRPS A, B, C, D T6...T2
 DIP CLII/III, DIV 1, GRPS E, F, G; T6...T3
 CL I Zone 0/1 AEx db IIC T6...T2 Ga/Gb
 Zone 21 AEx tb IIIC T85 °C...T250 °C Db
 (-40°C ≤ Ta ≤ +70°C)⁽¹⁴⁾; Type 4X/IP6X
 SINGLE SEAL

Specific Conditions of Use (X):

1. Flamepath joints are not for repair. Contact the manufacturer.
2. Plastic wire-on tag, Plastic part of Process Seal Antenna and Non-standard paint options (paint options other than Rosemount Blue) may cause risk from Electrostatic discharge. Avoid installation that could cause electrostatic build-up, and only clean with a damp cloth.
3. Appropriate cable, glands, and plugs need to be suitable for a temperature of 5°C greater than the maximum specified ambient temperature for location where installed.
4. The Transmitter can be installed in the boundary wall between a Zone 0 and Zone 1 area. In this configuration, the process connection is installed in Zone 0, while the transmitter housing is installed in Zone 1. Refer to Control Drawing D7000002-885.
5. Cable entries must be used which maintain the ingress protection of the enclosure to at least IP6X and/or Type 4X rating. To maintain the ingress protection ratings. Covers and Sensor Module to be fully tightened and PTFE tape or pipe dope is required for cable entries and blanking plugs. See Instruction Manual on application requirements.
6. Install per Control drawing D7000002-885.
7. Using the box provided on the nameplate, the User shall permanently mark the type of protection chosen for the specific installation. Once the type of protection has been marked it shall not be changed.
8. Display glass shall be positioned in such a way as to minimize the risk of mechanical impact.

(14) Other temperature ranges may apply, see Specific Conditions of Use (X).

9. The applicable temperature class, ambient temperature range and process temperature range of the equipment is as follows;

Table 25: For Divisions:

Temperature class / Maximum surface temperature	Ambient temperature range	Process temperature range
Division Gas groups:		
T2	$-40^{\circ}\text{C} \leq T_a \leq 70^{\circ}\text{C}$	-40°C to 250°C
T3	$-40^{\circ}\text{C} \leq T_a \leq 70^{\circ}\text{C}$	-40°C to 195°C
T4	$-40^{\circ}\text{C} \leq T_a \leq 70^{\circ}\text{C}$	-40°C to 130°C
T5	$-40^{\circ}\text{C} \leq T_a \leq 70^{\circ}\text{C}$	-40°C to 95°C
T6	$-40^{\circ}\text{C} \leq T_a \leq 70^{\circ}\text{C}$	-40°C to 80°C
Division Dust groups:		
T3	$-50^{\circ}\text{C} \leq T_a \leq 70^{\circ}\text{C}$	-50°C to 160°C
T4	$-50^{\circ}\text{C} \leq T_a \leq 70^{\circ}\text{C}$	-50°C to 130°C
T5	$-50^{\circ}\text{C} \leq T_a \leq 70^{\circ}\text{C}$	-50°C to 95°C
T6	$-50^{\circ}\text{C} \leq T_a \leq 70^{\circ}\text{C}$	-50°C to 80°C

Table 26: For Zones:

Temperature class / Maximum surface temperature	Ambient temperature range	Process temperature range
Zone Gas groups:		
T2	$-50^{\circ}\text{C} \leq T_a \leq 70^{\circ}\text{C}$	-50°C to 250°C
T3	$-50^{\circ}\text{C} \leq T_a \leq 70^{\circ}\text{C}$	-50°C to 195°C
T4	$-50^{\circ}\text{C} \leq T_a \leq 70^{\circ}\text{C}$	-50°C to 130°C
T5	$-50^{\circ}\text{C} \leq T_a \leq 70^{\circ}\text{C}$	-50°C to 95°C
T6	$-50^{\circ}\text{C} \leq T_a \leq 70^{\circ}\text{C}$	-50°C to 80°C
Zone Dust groups:		
T250°C	$-60^{\circ}\text{C} \leq T_a \leq 70^{\circ}\text{C}$	-60°C to 250°C
T200°C	$-60^{\circ}\text{C} \leq T_a \leq 70^{\circ}\text{C}$	-60°C to 195°C
T135°C	$-60^{\circ}\text{C} \leq T_a \leq 70^{\circ}\text{C}$	-60°C to 130°C
T100°C	$-60^{\circ}\text{C} \leq T_a \leq 70^{\circ}\text{C}$	-60°C to 95°C
T85°C	$-60^{\circ}\text{C} \leq T_a \leq 70^{\circ}\text{C}$	-60°C to 80°C

IS Intrinsic Safety (IS), Non-Incendive (NI)

Certificate: FM-US FM16US0010X

Standards: FM Class 3600 – 2011; FM Class 3610 – 2015; FM Class 3611 – 2016; FM Class 3810 – 2005; ANSI/ISA 60079-0 – 2013; ANSI/ISA 60079-11 – 2013; ANSI/ISA 60079-26 – 2011; ANSI/NEMA 250 – 1991; ANSI/IEC 60529 – 2004; ANSI/ISA 12.27.01:2011

Markings: IS CL I, II, III DIV 1, GRPS A-G T4...T2
 NI CL I, DIV 2, GRPS A-D T4...T2
 S CL II, III DIV 2, GRPS E-G T4...T3
 CL I Zone 0 AEx ia IIC T4...T2 Ga

CL I Zone 0/1 AEx ib IIC T4...T2 Ga/Gb
 Zone 20 AEx ia IIIC T85°C...T250°C Da
 (-60°C ≤ Ta ≤ +70°C)
 When installed per Control Drawing D7000002-885

SINGLE SEAL

Safety parameter	HART®
Voltage U _i	30 V
Current I _i	133 mA
Power P _i	1.0 W
Capacitance C _i	7.3 nF
Inductance L _i	0

Specific Conditions of Use (X):

1. The Model 5408 Level Transmitter will not pass the 500Vrms dielectric strength test between the circuits and the earth ground. This must be taken into account during installation.
2. Plastic wire-on tag, Plastic part of Process Seal Antenna and Non-standard paint options (paint options other than Rosemount Blue) may cause risk from Electrostatic discharge. Avoid installation that could cause electrostatic build-up, and only clean with a damp cloth.
3. Appropriate cable, glands, and plugs need to be suitable for a temperature of 5°C greater than the maximum specified ambient temperature for location where installed.
4. The Transmitter can be installed in the boundary wall between a Zone 0 and Zone 1 area. In this configuration, the process connection is installed in Zone 0, while the transmitter housing is installed in Zone 1. Refer to Control Drawing D7000002-885.
5. Using the box provided on the nameplate, the User shall permanently mark the type of protection chosen for the specific installation. Once the type of protection has been marked it shall not be changed.
6. The applicable temperature class, ambient temperature range and process temperature range if the equipment is as follows;

Table 27: For Divisions:

Temperature class / Maximum surface temperature	Ambient temperature range	Process temperature range
Division Gas groups:		
T2	-60°C ≤ Ta ≤ 70°C	-60°C to 250°C
T3	-60°C ≤ Ta ≤ 70°C	-60°C to 195°C
T4	-60°C ≤ Ta ≤ 70°C	-60°C to 130°C
Division Dust groups:		
T3	-60°C ≤ Ta ≤ 70°C	-60°C to 160°C
T4	-60°C ≤ Ta ≤ 70°C	-60°C to 130°C
T5	-60°C ≤ Ta ≤ 70°C	-60°C to 95°C
T6	-60°C ≤ Ta ≤ 70°C	-60°C to 80°C

Table 28: For Zones:

Temperature class / Maximum surface temperature	Ambient temperature range	Process temperature range
Zone Gas groups:		

Table 28: For Zones: (continued)

Temperature class / Maximum surface temperature	Ambient temperature range	Process temperature range
T2	$-60^{\circ}\text{C} \leq T_a \leq 70^{\circ}\text{C}$	-60°C to 250°C
T3	$-60^{\circ}\text{C} \leq T_a \leq 70^{\circ}\text{C}$	-60°C to 195°C
T4	$-60^{\circ}\text{C} \leq T_a \leq 70^{\circ}\text{C}$	-60°C to 130°C
Zone Dust groups:		
T250°C	$-60^{\circ}\text{C} \leq T_a \leq 70^{\circ}\text{C}$	-60°C to 250°C
T200°C	$-60^{\circ}\text{C} \leq T_a \leq 70^{\circ}\text{C}$	-60°C to 195°C
T135°C	$-60^{\circ}\text{C} \leq T_a \leq 70^{\circ}\text{C}$	-60°C to 130°C
T100°C	$-60^{\circ}\text{C} \leq T_a \leq 70^{\circ}\text{C}$	-60°C to 95°C
T85°C	$-60^{\circ}\text{C} \leq T_a \leq 70^{\circ}\text{C}$	-60°C to 80°C

Canada

E6 Explosionproof, Dust-Ignitionproof

Certificate: FM-C FM16CA0011X

Standards: C22.2 NO. 0.4-04:2004 (R2013), C22.2 NO. 0.5-16:2016, C22.2 No. 25-1966:1966 (R:2014), C22.2 No.30-M1986:1986 (R:2012), C22.2 No.94-M91:1991 (R:2011), C22.2 No. 1010.1:2004, CAN/CSA C22.2 No. 60079-0:2015 Ed. 3, C22.2 No. 60079-1:2016 Ed. 3, C22.2 No. 60079-26:2016; CAN/CSA-C22.2 No. 60079-31:2015, C22.2. 60529:2005 (R:2015), ANSI/ISA 12.27.01:2011

Markings: XP CLI, DIV 1, GRPS A-D T6...T2
 DIP CLII/III, DIV 1, GRPS E-G; T6...T3
 Ex db IIC T6...T3 Gb
 Ex tb IIIC T85 °C...T250°C Db
 ($-40^{\circ}\text{C} \leq T_a \leq +70^{\circ}\text{C}$) ⁽¹⁵⁾; Type 4X/IP6X
 SINGLE SEAL

Specific Conditions of Use (X):

1. Flamepath joints are not for repair. Contact the manufacturer.
2. Plastic wire-on tag, Plastic part of Process Seal Antenna and Non-standard paint options (paint options other than Rosemount Blue) may cause risk from Electrostatic discharge. Avoid installation that could cause electrostatic build-up, and only clean with a damp cloth.
3. Appropriate cable, glands, and plugs need to be suitable for a temperature of 5°C greater than the maximum specified ambient temperature for location where installed.
4. Metric Field Wiring Entries are not allowed for Divisions.
5. The Transmitter can be installed in the boundary wall between a Zone 0 and Zone 1 area. In this configuration, the process connection is installed in Zone 0, while the transmitter housing is installed in Zone 1. Refer to Control Drawing D7000002-885.
6. Cable entries must be used which maintain the ingress protection of the enclosure to at least IP6X and/or Type 4X rating. To maintain the ingress protection ratings. Covers and Sensor Module to be fully tightened and PTFE tape or pipe dope is required for cable entries and blanking plugs. See Instruction Manual on application requirements.

(15) Other temperature ranges may apply, see Specific Conditions of Use (X).

7. Install per Control Drawing D7000002-885.
8. Using the box provided on the nameplate, the User shall permanently mark the type of protection chosen for the specific installation. Once the type of protection has been marked it shall not be changed.
9. Display glass shall be positioned in such a way as to minimize the risk of mechanical impact.
10. The applicable temperature class, ambient temperature range and process temperature range of the equipment is as follows;

Table 29: For Divisions:

Temperature class / Maximum surface temperature	Ambient temperature range	Process temperature range
Division Gas groups:		
T2	-40°C ≤ Ta ≤ 70°C	-40°C to 250°C
T3	-40°C ≤ Ta ≤ 70°C	-40°C to 195°C
T4	-40°C ≤ Ta ≤ 70°C	-40°C to 130°C
T5	-40°C ≤ Ta ≤ 70°C	-40°C to 95°C
T6	-40°C ≤ Ta ≤ 70°C	-40°C to 80°C
Division Dust groups:		
T3	-50°C ≤ Ta ≤ 70°C	-50°C to 160°C
T4	-50°C ≤ Ta ≤ 70°C	-50°C to 130°C
T5	-50°C ≤ Ta ≤ 70°C	-50°C to 95°C
T6	-50°C ≤ Ta ≤ 70°C	-50°C to 80°C

Table 30: For Zones:

Temperature class / Maximum surface temperature	Ambient temperature range	Process temperature range
Zone Gas groups:		
T2	-50°C ≤ Ta ≤ 70°C	-50°C to 250°C
T3	-50°C ≤ Ta ≤ 70°C	-50°C to 195°C
T4	-50°C ≤ Ta ≤ 70°C	-50°C to 130°C
T5	-50°C ≤ Ta ≤ 70°C	-50°C to 95°C
T6	-50°C ≤ Ta ≤ 70°C	-50°C to 80°C
Zone Dust groups:		
T250°C	-60°C ≤ Ta ≤ 70°C	-60°C to 250°C
T200°C	-60°C ≤ Ta ≤ 70°C	-60°C to 195°C
T135°C	-60°C ≤ Ta ≤ 70°C	-60°C to 130°C
T100°C	-60°C ≤ Ta ≤ 70°C	-60°C to 95°C
T85°C	-60°C ≤ Ta ≤ 70°C	-60°C to 80°C

I6 Intrinsically Safe and Non-Incendive Systems

Certificate: FM-C FM16CA0011X

Standards: C22.2 NO. 0.4-04:2004 (R2013), C22.2 NO. 0.5-16:2016, C22.2 No. 25-1966:1966 (R:2014), C22.2 No.94-M91:1991 (R:2011), C22.2 No. 213-16:2016, C22.2 No. 1010.1:2004, CAN/CSA C22.2 No. 60079-0:2015 Ed. 3, CAN/CSAC22.2 No. 60079-11:2014 Ed. 2, CAN/CSAC22.2 No. 60079-15:2015 Ed.2, C22.2 No. 60079-26:2016, C22.2. 60529:2005 (R:2015); ANSI/ISA 12.27.01:2011

Markings: IS CL I, II, III DIV 1, GRPS A-G T4...T2
 NI CL I, DIV 2, GRPS A-D T4...T2
 S CL II, III DIV 2, GRPS E-G T4...T3
 Ex ia IIC T4...T2 Ga
 Ex ib IIC T4...T2 Ga/Gb
 Ex ia IIIC T85°C...T250°C Da
 (-60°C ≤ Ta ≤ +70°C)
 When installed per Control Drawing D7000002-885
 SINGLE SEAL

Safety parameter	HART
Voltage U _i	30 V
Current I _i	133 mA
Power P _i	1.0 W
Capacitance C _i	7.3 nF
Inductance L _i	0

Specific Conditions of Use (X):

1. The Model 5408 Level Transmitter will not pass the 500Vrms dielectric strength test between the circuits and the earth ground. This must be taken into account during installation.
2. Plastic wire-on tag, Plastic part of Process Seal Antenna and Non-standard paint options (paint options other than Rosemount Blue) may cause risk from Electrostatic discharge. Avoid installation that could cause electrostatic build-up, and only clean with a damp cloth.
3. Appropriate cable, glands, and plugs need to be suitable for a temperature of 5°C greater than the maximum specified ambient temperature for location where installed.
4. The Transmitter can be installed in the boundary wall between a Zone 0 and Zone 1 area. In this configuration, the process connection is installed in Zone 0, while the transmitter housing is installed in Zone 1. Refer to Control Drawing D7000002-885.
5. Using the box provided on the nameplate, the User shall permanently mark the type of protection chosen for the specific installation. Once the type of protection has been marked it shall not be changed.
6. The applicable temperature class, ambient temperature range and process temperature range of the equipment is as follows;

Table 31: For Divisions:

Temperature class / Maximum surface temperature	Ambient temperature range	Process temperature range
Division Gas groups:		
T2	-60°C ≤ Ta ≤ 70°C	-60°C to 250°C
T3	-60°C ≤ Ta ≤ 70°C	-60°C to 195°C
T4	-60°C ≤ Ta ≤ 70°C	-60°C to 130°C
Division Dust groups:		
T3	-60°C ≤ Ta ≤ 70°C	-60°C to 160°C
T4	-60°C ≤ Ta ≤ 70°C	-60°C to 130°C
T5	-60°C ≤ Ta ≤ 70°C	-60°C to 95°C
T6	-60°C ≤ Ta ≤ 70°C	-60°C to 80°C

Table 32: For Zones:

Temperature class / Maximum surface temperature	Ambient temperature range	Process temperature range
Zone Gas groups:		
T2	-60°C ≤ Ta ≤ 70°C	-60°C to 250°C
T3	-60°C ≤ Ta ≤ 70°C	-60°C to 195°C
T4	-60°C ≤ Ta ≤ 70°C	-60°C to 130°C
Zone Dust groups:		
T250°C	-60°C ≤ Ta ≤ 70°C	-60°C to 250°C
T200°C	-60°C ≤ Ta ≤ 70°C	-60°C to 195°C
T135°C	-60°C ≤ Ta ≤ 70°C	-60°C to 130°C
T100°C	-60°C ≤ Ta ≤ 70°C	-60°C to 95°C
T85°C	-60°C ≤ Ta ≤ 70°C	-60°C to 80°C

Europe

E1 ATEX Flameproof

Certificate: FM15ATEX0055X

Standards: EN 60079-0:2012, EN 60079-1:2014, EN 60079-26:2015, EN 60079-31:2014, EN 60529+A1+A2:2013

Markings: 

II 1/2G Ex db IIC T6...T2 Ga/Gb

II 2D Ex tb IIIC T85°C... T250°C Db, IP6X

(-60°C ≤ Ta ≤ +70 °C)

Specific Conditions of Use (X):

1. Flamepath joints are not for repair. Contact the manufacturer.
2. Plastic wire-on tag, Plastic part of Process Seal Antenna and Non-standard paint options (paint options other than Rosemount Blue) may cause risk from Electrostatic discharge. Avoid installation that could cause electrostatic build-up, and only clean with a damp cloth.
3. Appropriate cable, glands, and plugs need to be suitable for a temperature of 5°C greater than the maximum specified ambient temperature for location where installed.
4. The Transmitter can be installed in the boundary wall between a Category 1 and Category 2 location. In this configuration, the process connection is installed in Category 1, while the transmitter housing is installed in Category 2. Refer to Control Drawing D7000002-885.
5. Cable entries must be used which maintain the ingress protection of the enclosure to at least IP6X. To maintain the ingress protection ratings. Covers and Sensor Module to be fully tightened and PTFE tape or pipe dope is required for cable entries and blanking plugs. See Instruction Manual on application requirements.
6. Install per Control Drawing D7000002-885.
7. Using the box provided on the nameplate, the User shall permanently mark the type of protection chosen for the specific installation. Once the type of protection has been marked it shall not be changed.
8. Display glass shall be positioned in such a way as to minimize the risk of mechanical impact.
9. The applicable temperature class, ambient temperature range and process temperature range of the equipment is as follows;

Temperature class / Maximum surface temperature	Ambient temperature range	Process temperature range
Gas & Dust groups:		
T2 / T250°C	-60°C ≤ Ta ≤ 70°C	-60°C to 250°C
T3 / T200°C	-60°C ≤ Ta ≤ 70°C	-60°C to 195°C
T4 / T135°C	-60°C ≤ Ta ≤ 70°C	-60°C to 130°C
T5 / T100°C	-60°C ≤ Ta ≤ 70°C	-60°C to 95°C
T6 / T85°C	-60°C ≤ Ta ≤ 70°C	-60°C to 80°C

I1 ATEX Intrinsic Safety

Certificate: FM15ATEX0055X

Standards: EN 60079-0:2012, EN 60079-11:2012, EN 60079-26:2015

Markings:



II 1G Ex ia IIC T4...T2 Ga

II 1/2G Ex ib IIC T4...T2 Ga/Gb

II 1D Ex ia IIIC T85°C...T250°C Da

(-60°C ≤ Ta ≤ +70°C)

Safety parameter	HART
Voltage U _i	30 V
Current I _i	133 mA
Power P _i	1.0 W
Capacitance C _i	7.3 nF
Inductance L _i	0

Specific Conditions of Use (X):

- The Model 5408 Level Transmitter will not pass the 500Vrms dielectric strength test between the circuits and the earth ground. This must be taken into account during installation.
- Plastic wire-on tag, Plastic part of Process Seal Antenna and Non-standard paint options (paint options other than Rosemount Blue) may cause risk from Electrostatic discharge. Avoid installation that could cause electrostatic build-up, and only clean with a damp cloth.
- Appropriate cable, glands, and plugs need to be suitable for a temperature of 5°C greater than the maximum specified ambient temperature for location where installed.
- The Transmitter can be installed in the boundary wall between a Category 1 and Category 2 location. In this configuration, the process connection is installed in Category 1, while the transmitter housing is installed in Category 2. Refer to Control Drawing D7000002-885.
- Using the box provided on the nameplate, the User shall permanently mark the type of protection chosen for the specific installation. Once the type of protection has been marked it shall not be changed.
- The applicable temperature class, ambient temperature range and process temperature range of the equipment is as follows;

Temperature class / Maximum surface temperature	Ambient temperature range	Process temperature range
Gas groups:		
T2	-60°C ≤ Ta ≤ 70°C	-60°C to 250°C
T3	-60°C ≤ Ta ≤ 70°C	-60°C to 195°C

Temperature class / Maximum surface temperature	Ambient temperature range	Process temperature range
T4	-60°C ≤ Ta ≤ 70°C	-60°C to 130°C
Dust groups:		
T250°C	-60°C ≤ Ta ≤ 70°C	-60°C to 250°C
T200°C	-60°C ≤ Ta ≤ 70°C	-60°C to 195°C
T135°C	-60°C ≤ Ta ≤ 70°C	-60°C to 130°C
T100°C	-60°C ≤ Ta ≤ 70°C	-60°C to 95°C
T85°C	-60°C ≤ Ta ≤ 70°C	-60°C to 80°C

N1 ATEX Type N: Non-Sparking

Certificate: FM15ATEX0056X

Standards: EN 60079-0:2012, EN 60079-15:2010

Markings: 
 II 3G Ex nA IIC T4...T2 Gc, IP65
 (-34°C ≤ Ta ≤ +70°C)
 V ≤ 42.4V, I ≤ 23 mA

Specific Conditions of Use (X):

1. The Model 5408 Level Transmitter will not pass the 500Vrms dielectric strength test between the circuits and the earth ground. This must be taken into account during installation.
2. Plastic part of Process Seal Antenna may cause risk from Electrostatic discharge. Avoid installation that could cause electrostatic build-up, and only clean with a damp cloth.
3. Cable entries must be used which maintain the ingress protection of the enclosure to at least IP65. To maintain the ingress protection ratings, Covers and Sensor Module to be fully tightened and PTFE tape or pipe dope is required for cable entries and blanking plugs. See Instruction Manual on application requirements.
4. The applicable temperature class, ambient temperature range and process temperature range of the equipment is as follows;

Temperature class	Ambient temperature range	Process temperature range
T2	-34°C ≤ Ta ≤ 70°C	-34°C to 250°C
T3	-34°C ≤ Ta ≤ 70°C	-34°C to 195°C
T4	-34°C ≤ Ta ≤ 70°C	-34°C to 130°C

International

E7 IECEx Flameproof

Certificate: IECEx FMG15.0033X

Standards: IEC 60079-0:2011, IEC 60079-1:2014; IEC 60079-26:2014, IEC 60079-31:2013

Markings: Ex db IIC T6...T2 Ga/Gb
 Ex tb IIIC T85 °C...T250°C Db IP6X
 (-60°C ≤ Ta ≤ +70 °C)

Specific Conditions of Use (X):

1. Flamepath joints are not for repair. Contact the manufacturer.
2. Plastic wire-on tag, Plastic part of Process Seal Antenna and Non-standard paint options (paint options other than Rosemount Blue) may cause risk from Electrostatic discharge. Avoid installation that could cause electrostatic build-up, and only clean with a damp cloth.
3. Appropriate cable, glands, and plugs need to be suitable for a temperature of 5°C greater than the maximum specified ambient temperature for location where installed.
4. The Transmitter can be installed in the boundary wall between EPL Ga and EPL Gb. In this configuration, the process connection is EPL Ga, while the transmitter housing is EPL Gb. Refer to Control Drawing D7000002-885.
5. Cable entries must be used which maintain the ingress protection of the enclosure to at least IP6X. To maintain the ingress protection ratings, Covers and Sensor Module to be fully tightened and PTFE tape or pipe dope is required for cable entries and blanking plugs. See Instruction Manual on application requirements.
6. Install per Control Drawing D7000002-885.
7. Using the box provided on the nameplate, the User shall permanently mark the type of protection chosen for the specific installation. Once the type of protection has been marked it shall not be changed.
8. Display glass shall be positioned in such a way as to minimize the risk of mechanical impact.
9. The applicable temperature class, ambient temperature range and process temperature range of the equipment is as follows:

Temperature class / Maximum surface temperature	Ambient temperature range	Process temperature range
Gas & Dust groups:		
T2 / T250°C	-60°C ≤ Ta ≤ 70°C	-60°C to 250°C
T3 / T200°C	-60°C ≤ Ta ≤ 70°C	-60°C to 195°C
T4 / T135°C	-60°C ≤ Ta ≤ 70°C	-60°C to 130°C
T5 / T100°C	-60°C ≤ Ta ≤ 70°C	-60°C to 95°C
T6 / T85°C	-60°C ≤ Ta ≤ 70°C	-60°C to 80°C

I7 IECEx Intrinsic Safety

- Certificate:** IECEx FMG15.0033X
- Standards:** IEC 60079-0:2011, IEC 60079-11:2011, IEC 60079-26:2014
- Markings:** Ex ia IIC T4...T2 Ga
 Ex ib IIC T4...T2 Ga/Gb
 Ex ia IIIC T85°C...T250°C Da
 (-60°C ≤ Ta ≤ +70°C)

Safety parameter	HART
Voltage U _i	30 V
Current I _i	133 mA
Power P _i	1.0 W
Capacitance C _i	7.3 nF
Inductance L _i	0

Specific Conditions of Use (X):

1. The Model 5408 Level Transmitter will not pass the 500Vrms dielectric strength test between the circuits and the earth ground. This must be taken into account during installation.
2. Plastic wire-on tag, Plastic part of Process Seal Antenna and Non-standard paint options (paint options other than Rosemount Blue) may cause risk from Electrostatic discharge. Avoid installation that could cause electrostatic build-up, and only clean with a damp cloth.
3. Appropriate cable, glands, and plugs need to be suitable for a temperature of 5°C greater than the maximum specified ambient temperature for location where installed.
4. The Transmitter can be installed in the boundary wall between EPL Ga and EPL Gb. In this configuration, the process connection is EPL Ga, while the transmitter housing is EPL Gb. Refer to Control Drawing D7000002-885.
5. Using the box provided on the nameplate, the User shall permanently mark the type of protection chosen for the specific installation. Once the type of protection has been marked it shall not be changed.
6. The applicable temperature class, ambient temperature range and process temperature range of the equipment is as follows;

Temperature class / Maximum surface temperature	Ambient temperature range	Process temperature range
Gas groups:		
T2	-60°C ≤ Ta ≤ 70°C	-60°C to 250°C
T3	-60°C ≤ Ta ≤ 70°C	-60°C to 195°C
T4	-60°C ≤ Ta ≤ 70°C	-60°C to 130°C
Dust groups:		
T250°C	-60°C ≤ Ta ≤ 70°C	-60°C to 250°C
T200°C	-60°C ≤ Ta ≤ 70°C	-60°C to 195°C
T135°C	-60°C ≤ Ta ≤ 70°C	-60°C to 130°C
T100°C	-60°C ≤ Ta ≤ 70°C	-60°C to 95°C
T85°C	-60°C ≤ Ta ≤ 70°C	-60°C to 80°C

N7 IECEx Type N: Non-Sparking

- Certificate:** IECEx FMG15.0033X
- Standards:** IEC 60079-0:2011, IEC 60079-15:2010
- Markings:** Ex nA IIC T4...T2 Gc
(-34°C ≤ Ta ≤ +70°C), IP65
V≤42.4V, I≤23 mA

Specific Conditions of Use (X):

1. The Model 5408 Level Transmitter will not pass the 500Vrms dielectric strength test between the circuits and the earth ground. This must be taken into account during installation.
2. Plastic part of Process Seal Antenna may cause risk from Electrostatic discharge. Avoid installation that could cause electrostatic build-up, and only clean with a damp cloth.
3. Cable entries must be used which maintain the ingress protection of the enclosure to at least IP65. To maintain the ingress protection ratings, Covers and Sensor Module to be fully tightened and PTFE tape or pipe dope is required for cable entries and blanking plugs. See Instruction Manual on application requirements.
4. The applicable temperature class, ambient temperature range and process temperature range of the equipment is as follows;

Temperature class / Maximum surface temperature	Ambient temperature range	Process temperature range
T2	$-34^{\circ}\text{C} \leq T_a \leq 70^{\circ}\text{C}$	-34°C to 250°C
T3	$-34^{\circ}\text{C} \leq T_a \leq 70^{\circ}\text{C}$	-34°C to 195°C
T4	$-34^{\circ}\text{C} \leq T_a \leq 70^{\circ}\text{C}$	-34°C to 130°C

Brazil

E2 INMETRO Flameproof

Certificate: UL-BR 17.0344X

Standards: ABNT NBR IEC 60079-0:2013, ABNT NBR IEC 60079-1:2016, ABNT NBR IEC 60079-26:2016, ABNT NBR IEC 60079-31:2014

Markings: Ex db IIC T6...T2 Ga/Gb
Ex tb III C T85°C...T250°C Db
Tamb = -60° to $+70^{\circ}\text{C}$; IP6X

Specific Conditions of Use (X):

1. See certificate.

I2 INMETRO Intrinsic Safety

Certificate: UL-BR 17.0344X

Standards: ABNT NBR IEC 60079-0:2013, ABNT NBR IEC 60079-11:2013, ABNT NBR IEC 60079-26:2016, ABNT NBR IEC 60079-31:2014

Markings: Ex ia IIC T4...T2 Ga
Ex ib IIC T4...T2 Ga/Gb
Ex ia IIIC T85°C...T250°C Da
Tamb = -60° to $+70^{\circ}\text{C}$

Safety parameter	HART
Voltage U_i	30 V
Current I_i	133 mA
Power P_i	1.0 W
Capacitance C_i	7.3 nF
Inductance L_i	0

Specific Conditions of Use (X):

1. See certificate.

N2 INMETRO Type N: Non-Sparking

Certificate: UL-BR 17.0344X

Standards: ABNT NBR IEC 60079-0:2013, ABNT NBR IEC 60079-15:2012
Markings: Ex nA IIC T4...T2 Gc
 Tamb = -34° to +70°C; IP65
 V≤42.4V, I≤23 mA

Specific Conditions of Use (X):

1. See certificate.

China

E3 Flameproof

Certificate: NEPSI GYJ17.1226X
Standards: GB3836.1/2/4/20-2010, GB12476.1/5-2013
Markings: Ex d IIC T6~T2 Ga/Gb
 Ex tD A21 IP6X T85°C~250°C
 Tamb = -60° to +70°C; IP6X

Specific Conditions of Use (X):

1. See certificate.

I3 Intrinsic Safety

Certificate: NEPSI GYJ17.1226X
Standards: GB3836.1/2/4/20-2010, GB12476.1/5-2013, GB12476.4-2010
Markings: Ex ia IIC T4~T2 Ga
 Ex ib IIC T4~T2 Ga/Gb
 Ex iaD 20 T85~250 Da
 Tamb = -60° to +70°C

Safety parameter	HART
Voltage U_i	30 V
Current I_i	133 mA
Power P_i	1.0 W
Capacitance C_i	7.3 nF
Inductance L_i	0

Specific Conditions of Use (X):

1. See certificate.

N3 Type N: Non-Sparking

Certificate:	NEPSI GYJ17.1226X
Standards:	GB3836.1-2010, GB3836.8-2014
Markings:	Ex nA IIC T4~T2 Gc Tamb = -34° to +70°C; IP65 V≤42.4V, I≤23 mA

Specific Conditions of Use (X):

1. See certificate.

India

Intrinsic Safety

Certificate:	PESO P403812
Markings:	Ex ia IIC T4...T2 Ga

Flameproof Safety

Certificate:	PESO P403810
Markings:	Ex db IIC T6...T2 Ga/Gb

Intrinsic Safety and Flameproof

Certificate:	PESO P402545
Markings:	Ex ia IIC T4...T2 Ga/Gb Ex db IIC T6...T2 Ga/Gb

Republic of Korea

IP Intrinsic Safety

Certificate:	KTL 17-KA4BO-0448X
Markings:	Ex ia IIC T4...T2 Ga Tamb = -60° to +70°C

Safety parameter	HART
Voltage U_i	30 V
Current I_i	133 mA
Power P_i	1.0 W
Capacitance C_i	7.3 nF
Inductance L_i	0

Specific Conditions of Use (X):

1. See certificate.

Additional certifications

QT Safety-certified to IEC 61508:2010 with certificate of FMEDA data

Certificate: exida ROS 15-01-149 C001 R1.0

Suitable for intended use

Compliant with NAMUR NE 95:2013, “Basic Principles of Homologation”.

U1 Overfill prevention

Certificate: Z-65.16-575

Application: TÜV tested and approved by DIBt for overfill prevention according to the German WHG regulations.

QA 3-A

Certificate Authorization Number: 3626

The following options are conforming to the 3-A Sanitary Standards, Number 74-06 (Sensors and Sensor Fittings and Connections):

- Process connection type:** C (Tri-Clamp)
- Process connection size:** 2, 3
- Antenna type:** SAA (Process Seal antenna)
- Antenna size:** 2, 3

The certification of the transmitter relies upon the following materials used in its construction:

Table 33: Product Contact Surfaces

Item	Material
Microwave launcher	PTFE fluoropolymer

Table 34: Nonproduct Contact Surfaces

Item	Material
Metal housing	Stainless steel 300 series or aluminium 360, painted with epoxy-polyester or polyurethane
Fasteners and plugs	Stainless steel 300 series
Seals	Nitrile rubber NBR, Ethylene propylene peroxide and FKM fluoroelastomer
Labels	Stainless steel 300 series, metallized polyester, polyester/polycarbonate

It is the responsibility of the user to ensure:

1. The materials listed in [Table 33](#) and [Table 34](#) are suitable for the media and cleaning/sanitizing processes.
2. The installation of the transmitter is drainable and cleanable.
3. That the joint/clamping between the transmitter and the nozzle is compatible with the tank pressure and media.
4. That for the application suitable cable entry devices are used and with appropriate ingress protection.
5. That any unused cable entries are sealed with suitable plugs to maintain the ingress protection ratings.

Dimensional drawings

Figure 20: Cone Antenna

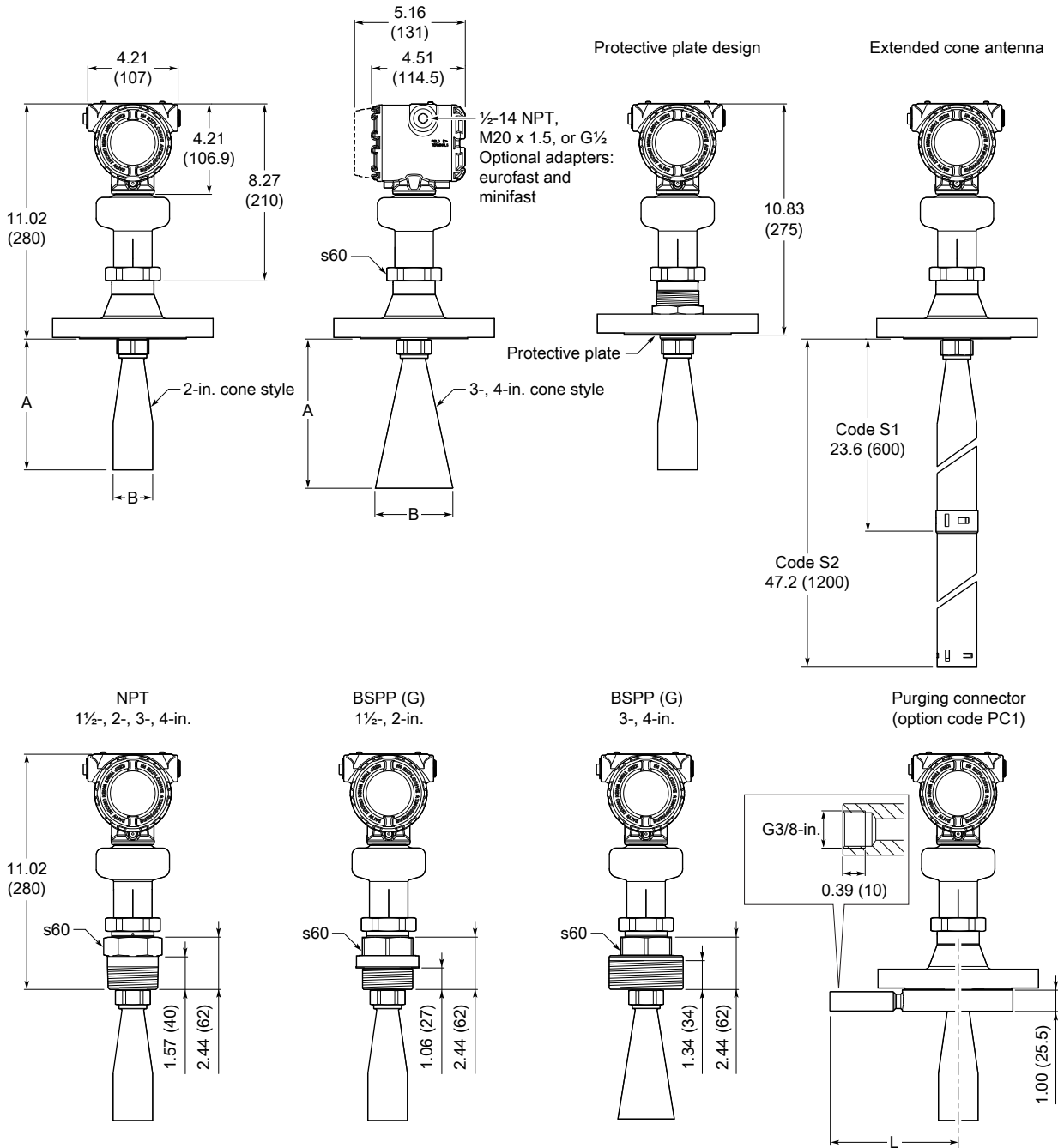

Dimensions are in inches (millimeters).

Table 35: Cone Antenna Dimensions

Cone size	A	B	L
2-in. (DN50)	6.10 in. (155 mm)	1.85 in. (47 mm)	5.39 in. (137 mm)
3-in. (DN80)	6.02 in. (153 mm)	2.64 in. (67 mm)	6.77 in. (172 mm)
4-in. (DN100)	6.93 in. (176 mm)	3.62 in. (92 mm)	7.80 in. (198 mm)

Figure 21: Process Seal Antenna

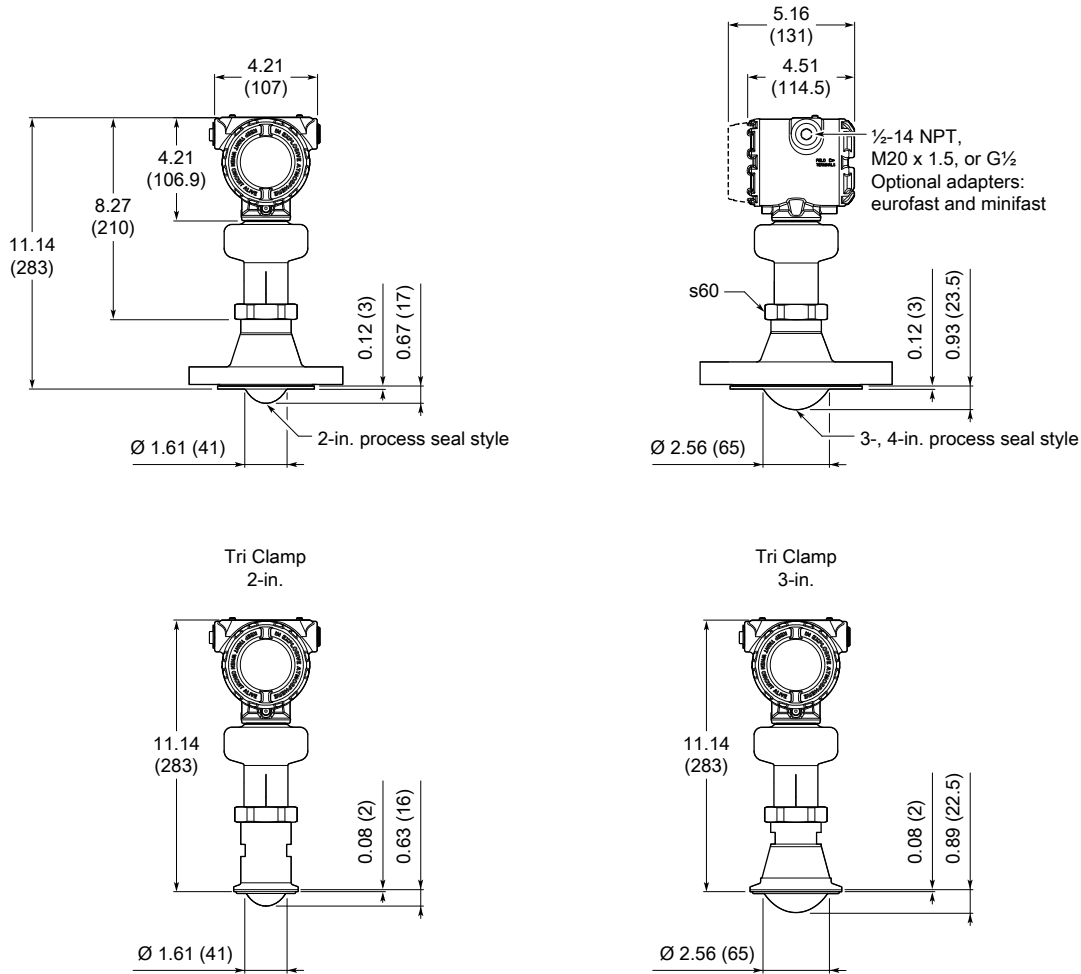

Dimensions are in inches (millimeters).

Figure 22: Parabolic Antenna

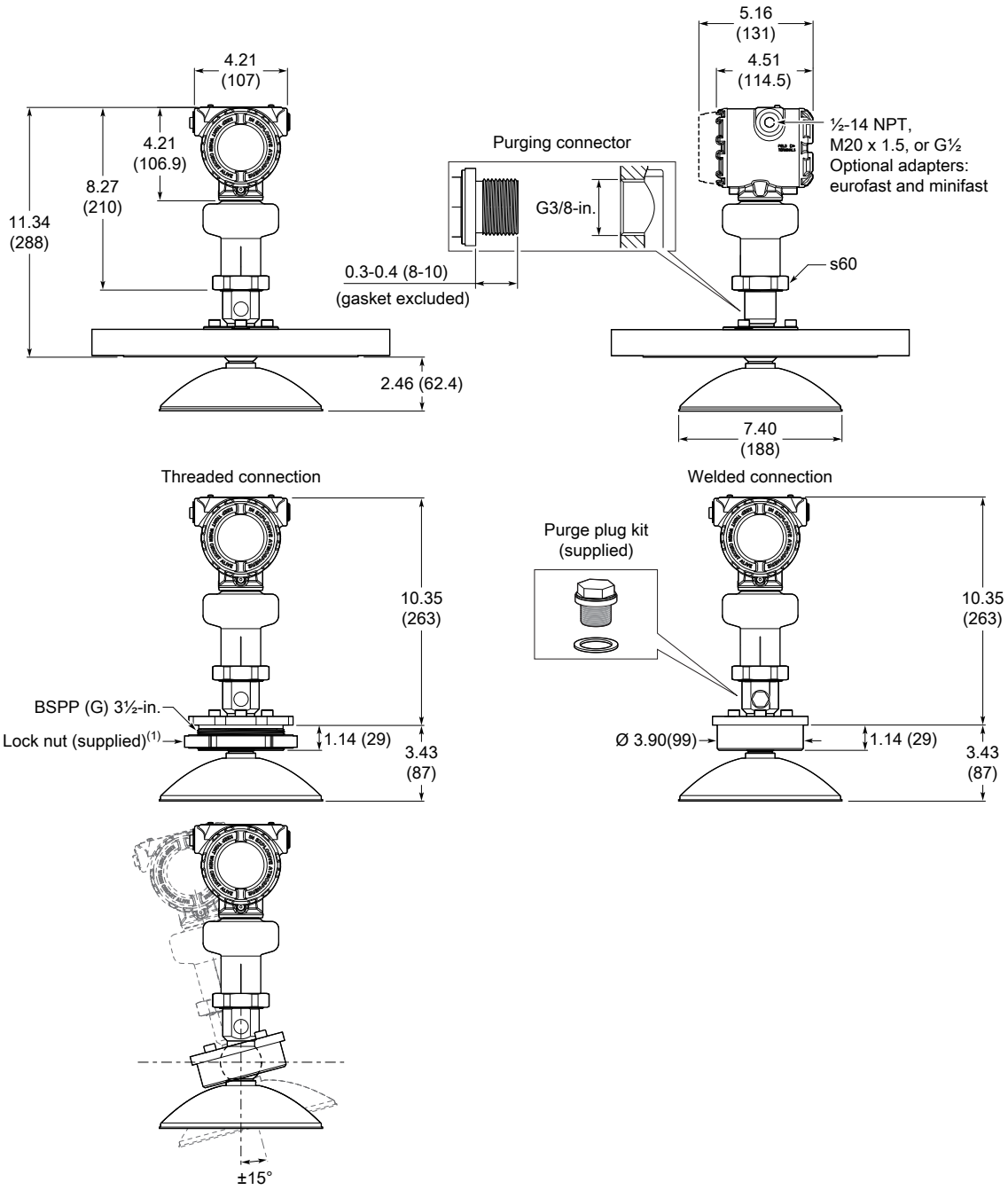

1. Maximum flange thickness (with lock nut): 0.59 in. (15 mm)

Dimensions are in inches (millimeters).

Figure 23: Bracket Mounting (Process Connection Type Code B)

Pipe mounting (vertical pipe)

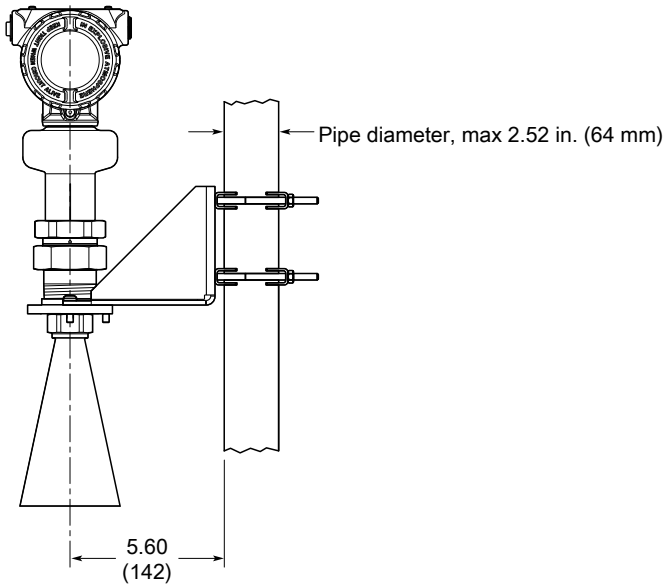

Pipe mounting (Horizontal pipe)

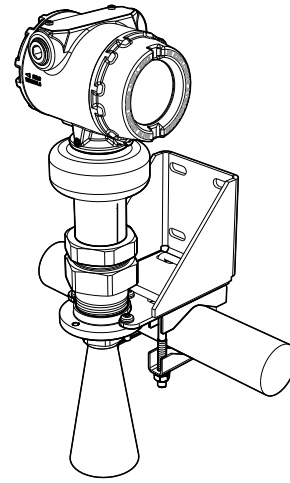

Wall mounting

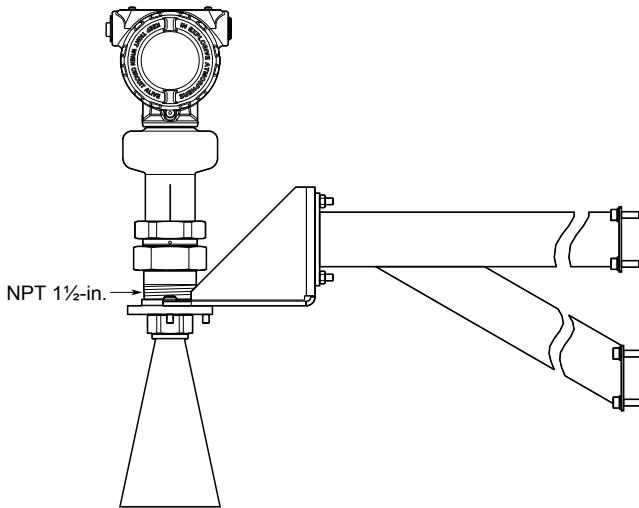

Hole pattern for wall mounting

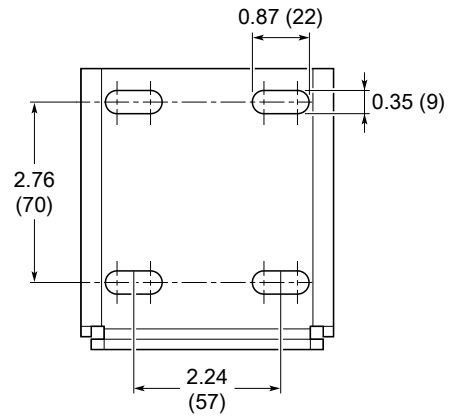

Dimensions are in inches (millimeters).

Standard flanges

Figure 24: Cone Antenna Flange Connection

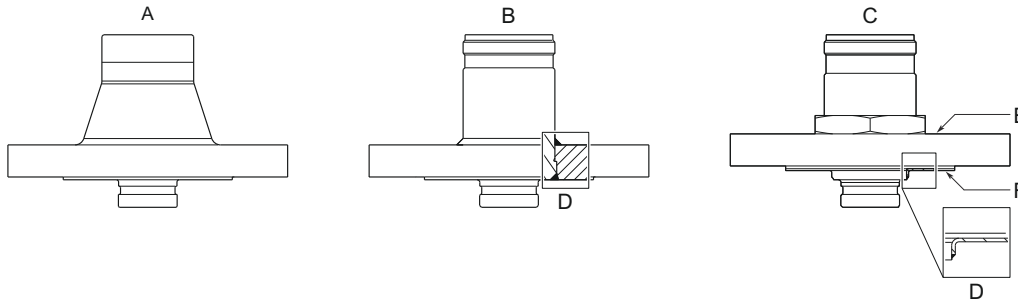

- A. Forged one-piece
- B. Welded construction
- C. Protective plate design
- D. Weld
- E. Backing flange
- F. Protective plate

Table 36: Standard Flanges for Cone Antenna

Standard	Face type ⁽¹⁾	Face surface finish, R _a	Material
ASME B16.5	Raised face	125-250 μin	316/316L SST
EN 1092-1	Type B1 raised face	3.2-12.5 μm	EN 1.4404
	Type A flat face	3.2-12.5 μm	EN 1.4404
JIS B2220	Raised face	3.2-6.3 μm	EN 1.4404

(1) Face gasket surface is serrated per mating standard.

Table 37: Cone Antennas with Protective Plate

Standard	Face type including protective plate	Plate surface finish, R _a	Material
ASME B16.5	Raised face	3.2-6.3 μm	316/316L SST
EN 1092-1	Raised face	3.2-6.3 μm	EN 1.4404
JIS B2220	Raised face	3.2-6.3 μm	EN 1.4404

Figure 25: Parabolic Antenna Flange Connection



Table 38: Standard Flanges for Parabolic Antenna

Standard	Face type ⁽¹⁾	Face surface finish	Material
ASME B16.5	Raised face	125-250 μin	316/316L SST
EN 1092-1	Type A flat face	3.2-12.5 μm	EN 1.4404
JIS B2220	Raised face	3.2-12.5 μm	EN 1.4404

(1) Face gasket surface is serrated per mating standard.

Global Headquarters

Emerson Automation Solutions
6021 Innovation Blvd
Shakopee, MN 55379 USA

📞 +1 800 999 9307 or +1 952 906 8888

📠 +1 952 949 7001

✉️ RFQ.RMD-RCC@Emerson.com

North America Regional Office

Emerson Automation Solutions
8200 Market Blvd.
Chanhassen, MN 55317, USA

📞 +1 800 999 9307 or +1 952 906 8888

📠 +1 952 949 7001

✉️ RMT-NA.RCCRF@Emerson.com

Latin America Regional Office

Emerson Automation Solutions
Sunrise, FL 33323, USA

📞 T +1 954 846 5030

📠 +1 954 846 5121

✉️ RFQ.RMD-RCC@Emerson.com

Europe Regional Office

Emerson Automation Solutions Europe
GmbH
Neuhofstrasse 19a P.O. Box 1046
CH 6340 Baar
Switzerland

📞 T +41 (0) 41 768 6111

📠 +41 (0) 41 768 6300

✉️ RFQ.RMD-RCC@Emerson.com

Asia Pacific Regional Office

Emerson Automation Solutions
1 Pandan Crescent
Singapore 128461
Republic of Singapore

📞 +65 6777 8211

📠 +65 6777 0947

✉️ Enquiries@AP.Emerson.com

Middle East and Africa Regional Office

Emerson Automation Solutions
Emerson FZE P.O. Box 17033
Jebel Ali Free Zone - South 2
Dubai, United Arab Emirates

📞 +971 4 8118100

📠 +971 4 8865465

✉️ RFQ.RMTMEA@Emerson.com

🌐 [Linkedin.com/company/Emerson-Automation-Solutions](https://www.linkedin.com/company/Emerson-Automation-Solutions)

🐦 [Twitter.com/Rosemount_News](https://twitter.com/Rosemount_News)

📘 [Facebook.com/Rosemount](https://www.facebook.com/Rosemount)

📺 [Youtube.com/user/RosemountMeasurement](https://www.youtube.com/user/RosemountMeasurement)

📍 [Google.com/+RosemountMeasurement](https://www.google.com/+RosemountMeasurement)

©2018 Emerson. All rights reserved.

Emerson Terms and Conditions of Sale are available upon request. The Emerson logo is a trademark and service mark of Emerson Electric Co. Rosemount is mark of one of the Emerson family of companies. All other marks are the property of their respective owners.